

LOCAL WINDS

CONTENTS

- Wind Frequency 645
 - Wind-speed Frequency 645
 - Wind-direction Frequency 646
- Wind-Turbine Power Generation 647
- Thermally Driven Circulations 648
 - Thermals 648
 - Cross-valley Circulations 649
 - Anabatic Wind 649
 - Katabatic Wind 652
 - Along-valley Winds 653
 - Sea breeze 654
- Open-Channel Hydraulics 657
 - Wave Speed 658
 - Froude Number - Part 1 659
 - Conservation of Air Mass 660
 - Hydraulic Jump 660
- Gap Winds 661
 - Basics 661
 - Short-gap Winds 661
 - Long-gap Winds 662
- Coastally Trapped Low-level (Barrier) Jets 664
- Mountain Waves 666
 - Natural Wavelength 666
 - Lenticular Clouds 666
 - Froude Number - Part 2 667
 - Mountain-wave Drag 668
- Streamlines, Streaklines, and Trajectories 668
- Bernoulli's Equation 669
 - Principles 669
 - Some Applications 672
 - Dynamic & Static Pressure & Temperature 672
 - Venturi Effect 674
- Downslope Winds 675
 - Bora 675
 - Foehns and Chinooks 676
- Canopy Flows 677
 - Forests and Crops 677
 - Cities 678
- Summary 679
- Exercises 680

17 Each locale has a unique landscape that creates or modifies the wind. These local winds affect where we choose to live, how we build our buildings, what we can grow, and how we are able to travel.

During synoptic high pressure (i.e., fair weather), some winds are generated locally by temperature differences. These gentle circulations include thermals, anabatic/katabatic winds, and sea breezes.

During synoptically windy conditions, mountains can modify the winds. Examples are gap winds, boras, hydraulic jumps, foehns/chinooks, and mountain waves.

WIND FREQUENCY

Wind-speed Frequency

Wind speeds are rarely constant. At any one location, wind speeds might be strong only rarely during a year, moderate many hours, light even more hours, and calm less frequently (Fig. 17.1). The number of times that a range ΔM of wind speeds occurred in the past is the **frequency** of occurrence. Dividing the frequency by the total number of wind measurements gives a **relative frequency**. The expectation that this same relative frequency will occur in the future is the **probability** (Pr).

The probability distribution of mean wind speeds M is described by the **Weibull distribution**:

$$Pr = \frac{\alpha \cdot \Delta M \cdot M^{\alpha-1}}{M_o^\alpha} \cdot \exp \left[- \left(\frac{M}{M_o} \right)^\alpha \right] \quad (17.1)$$

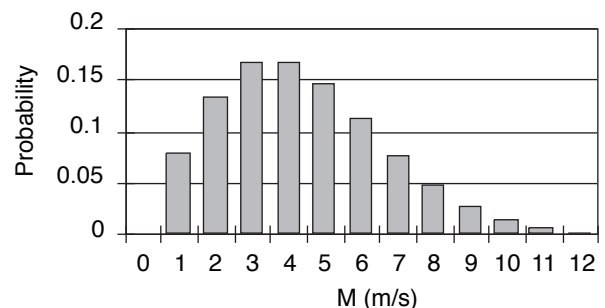



Figure 17.1 Wind-speed M probability (relative frequency) for a Weibull distribution with parameters $\alpha = 2$ and $M_o = 5$ m/s.



"Meteorology for Scientists and Engineers, 3rd Edition" by Roland Stull is licensed under a Creative Commons Attribution-NonCommercial-ShareAlike 4.0 International License. To view a copy of the license, visit <http://creativecommons.org/licenses/by-nc-sa/4.0/>. This work is available at http://www.eos.ubc.ca/books/Practical_Meteorology/.

Solved Example

Given $M_o = 5 \text{ m/s}$ and $\alpha = 2$, what is the probability that the wind speed will be between 5.5 and 6.5 m/s?

Solution

Given: $M_o = 5 \text{ m/s}$, $\alpha = 2$, $\Delta M = 6.5 - 5.5 \text{ m/s} = 1 \text{ m/s}$, $M = 6 \text{ m/s}$

Find: $Pr = ?$ (dimensionless)

Use eq. (17.1):

$$Pr = \frac{2 \cdot (1\text{m/s}) \cdot (6\text{m/s})^{2-1}}{(5\text{m/s})^2} \cdot \exp\left[-\left(\frac{6\text{m/s}}{5\text{m/s}}\right)^2\right]$$

$$= 0.114 = \mathbf{11.4\%}$$

Check: Units OK. Physics OK.

Discussion: This agrees with Fig. 17.1 at $M = 6 \text{ m/s}$, which had the same parameters as this example. To get a sum of probabilities that is very close to 100%, use a smaller bin size ΔM and be sure not to cut off the tail of the distribution at high wind speeds.

where Pr is the probability (or relative frequency) of wind speed $M \pm 0.5 \cdot \Delta M$. Such wind-speed variations are caused by synoptic, mesoscale, local and boundary-layer processes.

Location parameter M_o is proportional to the mean wind speed. For **spread parameter** α , smaller α causes wider spread of winds about the mean. Values of the parameters and the corresponding distribution shape vary from place to place.

The **bin size** or **resolution** is ΔM . For example, the column plotted in Fig. 17.1 for $M = 3 \text{ m/s}$ is the probability that the wind is between 2.5 and 3.5 m/s. The width of each column in the histogram is $\Delta M = 1 \text{ m/s}$. The sum of probabilities for all wind speeds should equal 1, meaning there is a 100% chance that the wind speed is between zero and infinity. Use this to check for errors. Eq. (17.1) is only approximate, so the sum of probabilities almost equals 1.

Use wind-speed distributions when estimating electrical-power generation by wind turbines, and when designing buildings and bridges to withstand extreme winds.

You can express extreme-wind likelihood as a **return period** (RP), which is equal to the total period of measurement divided by the number of times the wind exceeded a threshold. For example, if winds exceeding 30 m/s occurred twice during the last century, then the return period for 30 m/s winds is $RP = (100 \text{ yr})/2 = 50 \text{ years}$. Faster winds occur less frequently, and have greater return periods.

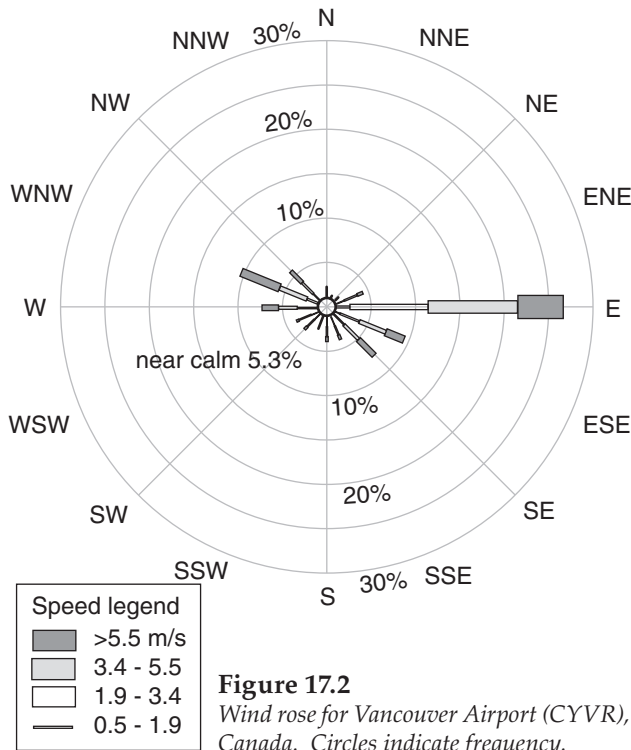

Figure 17.2
Wind rose for Vancouver Airport (CYVR), Canada. Circles indicate frequency.

Wind-direction Frequency

By counting the frequency of occurrence that winds came from each compass direction (N, NNE, NE, etc.) over a period such as 10 years, and then plotting that frequency on a polar graph, the result is called a **wind rose**. For example, Fig. 17.2 shows the wind rose for Vancouver Airport (CYVR).

The total length of each wind line gives the total frequency of any wind speed from that direction, while the width (or color) of the line subdivides that frequency into the portions associated with various wind speeds. (Not all wind roses are subdivided by wind speed.) The frequency of calm winds is usually written in the center of the circle if it fits, or is indicated off to the side. The sum of all the frequencies (including calm) should total 100%. At a glance, the longest lines indicate the predominant wind directions for any location.

For example, at Vancouver Airport, East (E) winds (winds from the east) are most frequent, followed by winds from the WNW and then from the ESE. Aircraft take-offs and landings are safer — and require shorter distances — if they are done into the wind. Hence, airports are built with their runways aligned parallel to the predominant wind directions (within

Solved Example

How frequent are east winds at Vancouver airport?

Solution

Use Fig. 17.2. Frequency $\approx \mathbf{26\%}$.

Discussion: This is the sum of 2% for $0.5 < M \leq 1.9$, plus 9% for $1.9 < M \leq 3.4$, plus 10% for $3.4 < M \leq 5.5$, plus 5% for $M > 5.5 \text{ m/s}$.

reason, as dictated by property boundaries and obstacles).

Fig. 17.3 shows that the runways at Vancouver Airport are appropriate for the wind climatology of the previous figure. The end of each runway is labeled with the magnetic compass direction (in tens of degrees; e.g., 12 means 120° magnetic) towards which the aircraft is flying when approaching that end of the runway from outside the airport. Thus, aircraft will use runway 30 for winds from 300°. Parallel runways are labeled as left (L) or right (R).

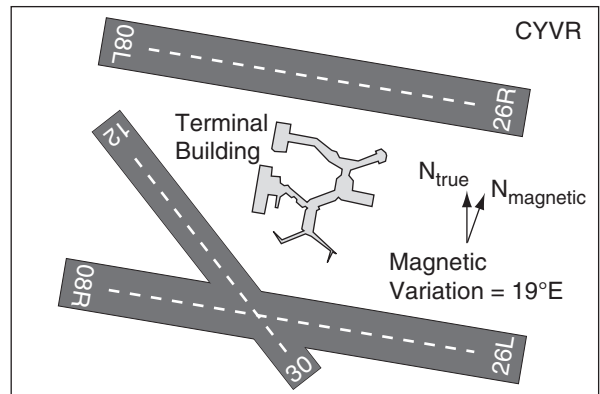

Figure 17.3

Plan view of runways at Vancouver International Airport (CYVR), Canada.

WIND-TURBINE POWER GENERATION

Kinetic energy of the wind is proportional to air mass times wind-speed squared. The rate at which this energy is blown through a wind turbine equals the wind speed. Thus, the theoretical power available from the wind is proportional to speed cubed:

$$\text{Power} = (\pi/2) \cdot \rho \cdot E \cdot R^2 \cdot M_{in}^3 \quad (17.2)$$

where R is the turbine-blade radius, M_{in} is incoming wind speed, and ρ is air density. Turbine efficiencies are $E = 30\%$ to 45% .

Faster winds and larger radii turbines allow greater power generation. Modern large wind turbines have a hub height (center of the turbine) of 80 m or more, to reach the faster winds higher above the surface. Turbines with radius of 30 m can generate up to 1.5 MW (mega Watts) of electricity, while blades of 40 m radius can generate up to 2.5 MW.

To see how a wind turbine works, consider Fig. 17.4 with an incoming wind speed M_{in} . Even before the wind reaches the disk swept out by the turbine blades, it feels the increased drag (higher pressure) from the turbine and begins to slow. It slows further while passing through the turbine (because the turbine is extracting energy from the wind), and slows more just behind the turbine due to the suction drag. Because the exit speed M_{out} is slower than the entrance speed, and because air-volume flow rate ($= M \cdot \text{cross-section area}$) is conserved, the diameter of the air that feels the influence of the turbine must increase as wind speed decreases.

Zero exit speed is impossible, because the exited air would block subsequent in-flow, preventing power production. Also, if the exit speed equals the entrance speed, then power production is zero because no energy is extracted from the wind. Thus, wind turbines are designed to have an optimum wind-speed decrease of $M_{out}/M_{in} = 1/3$ (see Beyond Algebra box on **Betz' Law**). Albert Betz showed that the theoretical maximum turbine efficiency at

Solved Example

A wind turbine at sea level uses a 30 m radius blade to convert a 10 m/s wind into electrical power at 40% efficiency. What is the theoretical power output?

Solution

Given: $\rho = 1.225 \text{ kg}\cdot\text{m}^{-3}$, $R = 30 \text{ m}$, $M_{in} = 10 \text{ m/s}$, $E = 0.4$
Find: $\text{Power} = ? \text{ kW}$ (Appendix A defines Watt, W)

Use eq. (17.2):

$$\begin{aligned} \text{Power} &= (\pi/2) \cdot (1.225 \text{ kg}\cdot\text{m}^{-3}) \cdot (0.4) \cdot (30\text{m})^2 \cdot (10\text{m/s})^3 \\ &= 6.93 \times 10^5 \text{ kg}\cdot\text{m}^2\cdot\text{s}^{-3} = \mathbf{693 \text{ kW}} \end{aligned}$$

Check: Units OK. Physics OK.

Discussion: To estimate annual wind turbine power, use the Weibull distribution to find the power for each wind speed separately, and add all these power increments. Do not use the annual average wind speed.

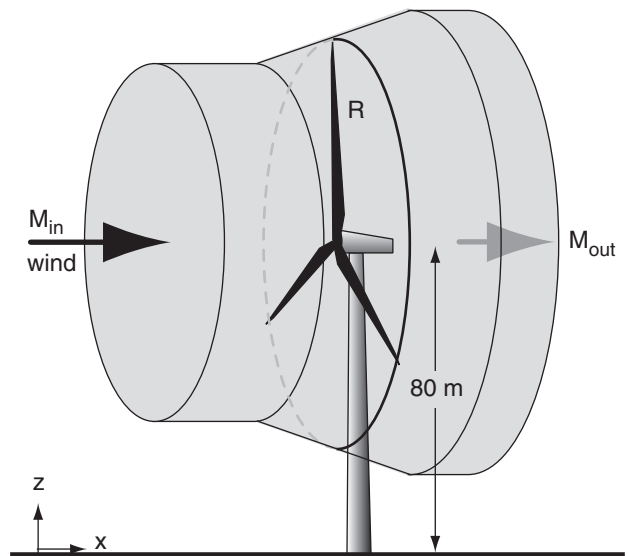

Figure 17.4

Wind turbine for electrical-power generation. Grey region shows the air that transfers some of its energy to the wind turbine.

BEYOND ALGEBRA • Betz' Law

In 1919 Albert Betz reasoned that the energy extracted by the turbine is the difference between incoming and outgoing kinetic energies:

$$Energy = 0.5 \cdot m \cdot M_{in}^2 - 0.5 \cdot m \cdot M_{out}^2 \quad (1)$$

where m is air mass and M is wind speed. The amount of air mass moving through the disk swept by the turbine during time interval Δt is the air density ρ times disk area ($A = \pi R^2$) times average speed:

$$m = \rho \cdot A \cdot 0.5(M_{in} + M_{out}) \cdot \Delta t \quad (2)$$

Plug this into the previous eq. and divide by Δt to get the power that the turbine can produce:

$$Power = 0.25 \cdot \rho \cdot A \cdot (M_{in} + M_{out}) \cdot (M_{in}^2 - M_{out}^2) \quad (3)$$

Divide this power by the power of the incoming wind $0.5 \cdot \rho \cdot A \cdot M_{in}^3$ to get a theoretical efficiency E_o :

$$E_o = (1/2) \cdot [1 - (M_{out}/M_{in})^2] \cdot [1 + (M_{out}/M_{in})] \quad (4)$$

Solve eq. (4) on a spreadsheet and plot E_o vs. M_{out}/M_{in} (see Fig. below) The peak in the curve gives

$$E_{max} = \underline{0.593} \quad \text{at} \quad M_{out}/M_{in} = \underline{1/3}.$$

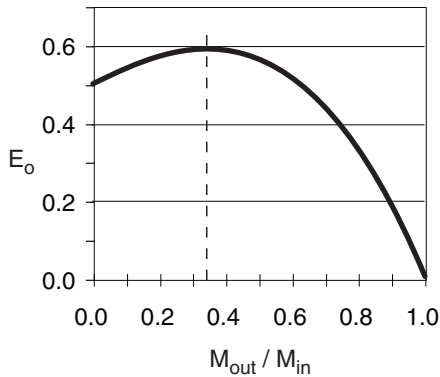

Fig. 17.a Theoretical turbine efficiencies using Betz' Law.

We can get the precise answer using calculus. Let the ratio of wind speeds be $r = M_{out}/M_{in}$, to simplify the notation. Use r in eq. (4):

$$E_o = (1/2) \cdot (1 - r^2) \cdot (1 + r) = (1/2) \cdot [1 + r - r^2 - r^3] \quad (5)$$

Differentiate E_o and set $dE_o/dr = 0$ to find the value of r at max E_o :

$$3r^2 + 2r - 1 = 0 \quad (6)$$

Solving this quadratic eq for r gives $r = 1/3$ and $r = -1$, for which the only physically reasonable answer is

$$r = M_{out}/M_{in} = \underline{1/3}.$$

Finally, plug this r into eq. (5) to get the max E_o :

$$E_{max} = (1/2) \cdot [1 + (1/3) - (1/9) - (1/27)] \quad (7)$$

Using a common denominator of 27, we find

$$E_{max} = (1/2) \cdot [32/27] = 16/27 = 0.593 = \underline{59.3\%}.$$

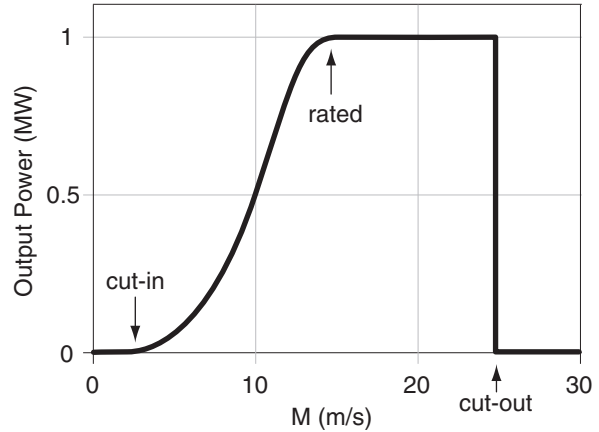

Figure 17.5 Typical power-output curve for a 1 MW wind turbine as a function of wind speed M .

this optimum speed is $E_{max} = 16/27 = 59.3\%$, which is known as **Betz' Limit**.

Wind turbines need a wind speed of at least 3 to 5 m/s to start turning. This is called the **cut-in** speed. As wind speed increases, so increases the amount of power generated. At its **rated** wind speed (8 to 15 m/s), the turbine is producing the maximum amount of electricity that the generators can handle. As wind speeds increase further, the aerodynamics of the blades are designed to change (via feathering the blades to reduce their pitch, or causing aerodynamic stalling) to keep the shaft rotation rate and electrical power generation nearly constant. Namely, the efficiency is intentionally reduced to protect the equipment. Finally, for wind speeds at or above a **cut-out** wind speed (25 - 30 m/s), turbine rotation is stopped to prevent damage. Fig. 17.5 shows the resulting idealized power output curve for a wind turbine.

THERMALLY DRIVEN CIRCULATIONS

Thermals

Thermals are warm updrafts of air, rising due to their buoyancy. Thermal diameters are nearly equal to their depth, z_i (Fig. 17.6).

A rising thermal feels drag against the surrounding environmental air (not against the ground). This drag is proportional to the square of the thermal updraft velocity relative to its environment. Neglecting advection and pressure deviations, the equation of vertical velocity W from the Dynamics chapter reduces to:

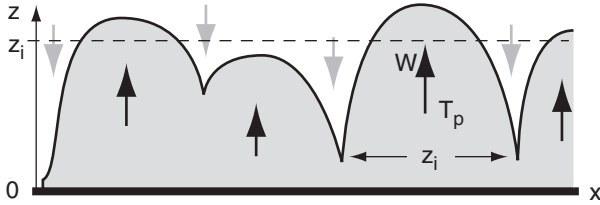

Figure 17.6
Thermals in a convective mixed layer of depth z_i . Black arrows show W updrafts in each thermal, and T_p is temperature of the thermal. Grey arrows show free-atmosphere air being entrained down into the convective mixed layer between the thermals.

$$\frac{\Delta W}{\Delta t} = \frac{\theta_{vp} - \theta_{ve}}{\bar{T}_{ve}} \cdot |g| - C_w \frac{W^2}{z_i} \quad (17.3)$$

tendency buoyancy turb. drag

where z_i is the mixed-layer (boundary-layer) depth, $C_w \approx 5$ is vertical drag coefficient, θ_v is virtual potential temperature, subscripts p and e indicate the air parcel (the thermal) and the environment, \bar{T}_{ve} is average absolute virtual temperature of the environment, and $|g| = 9.8 \text{ m}\cdot\text{s}^{-2}$ is gravitational acceleration.

At steady state, the acceleration is near zero ($\Delta W/\Delta t \approx 0$). Eq. (17.3) can be solved for the updraft speed of buoyant thermals (i.e., of warm air parcels):

$$W = \sqrt{\frac{|g| \cdot z_i (\theta_{vp} - \theta_{ve})}{C_w \bar{T}_{ve}}} \quad (17.4)$$

Thus, warmer thermals in deeper boundary layers have greater updraft speeds.

This equation also applies to deeper convection at the synoptic and mesoscales, such as weak updrafts in thunderstorms that rise to the top of the troposphere. For that case, z_i is the depth of the troposphere, and the temperature difference is that between the mid-cloud and the surrounding environment at the same height. For stronger updrafts and downdrafts in thunderstorms, the pressure deviation term of the equation of vertical motion must also be included (see the Thunderstorm chapters).

Cross-valley Circulations

(Circulations perpendicular to the valley axis.)

Anabatic Wind

During daytime in synoptically calm conditions (high-pressure center) with mostly clear skies, the sunlight heats mountain slopes. The warm mountain surface heats the neighboring air, which then rises. However, instead of rising vertically like thermals, the rising air hugs the slope as it rises. This warm turbulent air rising upslope is called an **anabatic**

Solved Example

Find the steady-state updraft speed in the middle of (a) a thermal in a boundary layer that is 1 km thick; and (b) a thunderstorm in a 11 km thick troposphere. The virtual temperature excess is 2°C for the thermal and 5°C for the thunderstorm, and $|g|/\bar{T}_{ve} = 0.0333 \text{ m}\cdot\text{s}^{-2}\cdot\text{K}^{-1}$.

Solution

Given: $|g|/\bar{T}_{ve} = 0.0333 \text{ m}\cdot\text{s}^{-2}\cdot\text{K}^{-1}$,
 (a) $z_i = 1000 \text{ m}$, $T_{vp} - T_{ve} = 2^\circ\text{C}$
 (b) $z_i = 11,000 \text{ m}$, $T_{vp} - T_{ve} = 5^\circ\text{C}$
 Find: $W = ? \text{ m/s}$

Use eq. (17.4): (a) For the thermal:

$$W = \sqrt{\frac{(0.0333 \text{ m}\cdot\text{s}^{-2}\cdot\text{K}^{-1})(1000 \text{ m})(2 \text{ K})}{5}} = \underline{3.65 \text{ m/s}}$$

(b) For the thunderstorm:

$$W = \sqrt{\frac{(0.0333 \text{ m}\cdot\text{s}^{-2}\cdot\text{K}^{-1})(11000 \text{ m})(5 \text{ K})}{5}} = \underline{19.1 \text{ m/s}}$$

Check: Units OK. Physics OK.

Discussion: Actually, neither thermal nor thunderstorm updrafts maintain a constant speed. However, this gives us an order-of-magnitude estimate. In convection, these updrafts must have downdrafts between them, but usually of larger diameter and slower speeds. Air-mass continuity requires that mass flow up must balance mass flow of air down, across any arbitrary horizontal plane. This would cause quite a bumpy ride in an airplane, which is why most aircraft pilots try to avoid areas of **convection** (regions filled with thermal or thunderstorm up- and downdrafts).

When I pilot a small plane, I try to stay above the atmospheric boundary layer for the whole flight (except take-off and landing) to have a smooth ride, and I avoid thunderstorms by flying around them.

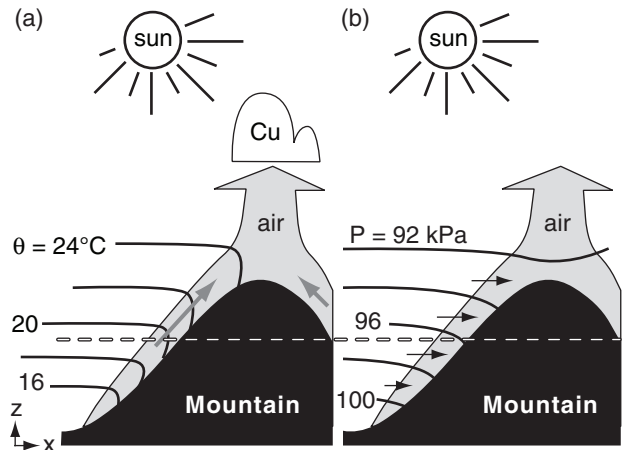

Figure 17.7
Anabatic winds (shaded grey). (a) Isentropes. (b) Isobars. Cu = cumulus cloud. θ = potential temperature. P = pressure.

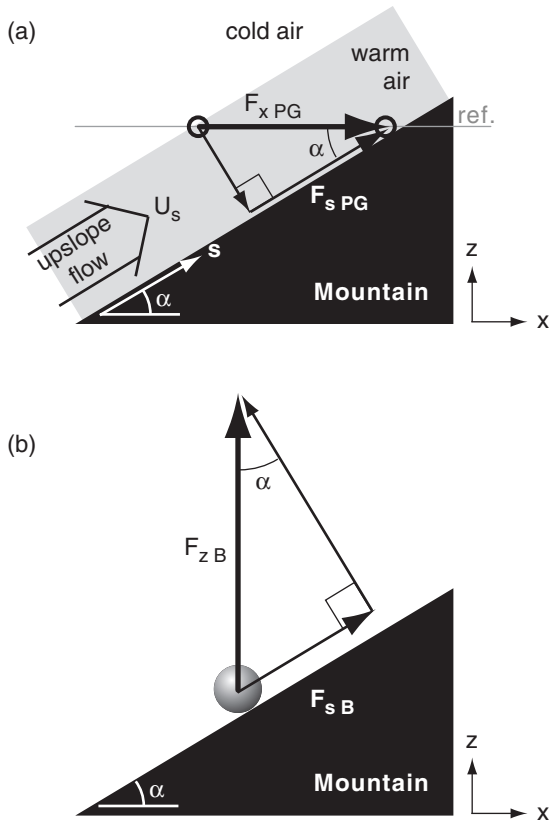

Figure 17.8
 Geometry of anabatic (upslope) flows. F is force, subscript s is in the up-slope direction, subscript PG is pressure gradient, and subscript B is buoyancy. $F_{sB} = F_{sPG}$.

Solved Example

Anabatic flow is 5°C warmer than the ambient environment of 15°C . Find the horizontal and along-slope pressure-gradient forces/mass, for a 30° slope.

Solution

Given: $T_e = 15^\circ\text{C} + 273 = 288\text{ K}$, $\Delta T = 5\text{ K}$, $\alpha = 30^\circ$
 Find: (a) $F_{xPG}/m = ?\text{ m}\cdot\text{s}^{-2}$, (b) $F_{sPG}/m = ?\text{ m}\cdot\text{s}^{-2}$

$$|g| \cdot \Delta T / T_e = (9.8\text{ m}\cdot\text{s}^{-2}) \cdot (5\text{ K}) / (288\text{ K}) = 0.17\text{ m}\cdot\text{s}^{-2}$$

Use eq. (17.5):

$$F_{xPG}/m = (0.17\text{ m}\cdot\text{s}^{-2}) \cdot \tan(30^\circ) = \mathbf{0.098\text{ m}\cdot\text{s}^{-2}}$$

Use eq. (17.6):

$$F_{sPG}/m = (0.17\text{ m}\cdot\text{s}^{-2}) \cdot \sin(30^\circ) = \mathbf{0.085\text{ m}\cdot\text{s}^{-2}}$$

Check: Units OK, because $\text{m}\cdot\text{s}^{-2} = \text{N}/\text{kg}$.

Discussion: Glider and hang-glider pilots use the anabatic updrafts to soar along mountain slopes and mountain tops.

wind (Fig. 17.7). Typical speeds are 3 to 5 m/s, and depths are hundreds of meters. The anabatic wind is the rising portion of a **cross-valley circulation**.

When the warm air reaches ridge top, it breaks away from the mountain and rises vertically, often joined by the updraft from the other side of the same mountain. Cumulus clouds called **anabatic clouds** can form just above ridge top in this updraft.

The dashed line in Fig. 17.7 is at a constant height above sea level. Following the line from left to right in Fig. 17.7a, potential temperatures of about 19°C are constant until reaching anabatic air near the mountain, where the potential temperature rises to about 21°C in this idealized illustration.

The temperature difference between the warmed air near the mountain and the cooler ambient air creates a small horizontal pressure gradient force (exaggerated in Fig. 17.7b) that holds the warm rising air against the mountain. To find this horizontal pressure-gradient force per unit mass m , use the hypsometric equation (see Focus box on next page):

$$\frac{F_{xPG}}{m} = -\frac{1}{\rho} \frac{\Delta P}{\Delta x} = |g| \frac{\Delta T}{T_e} \cdot \tan(\alpha) \quad (17.5)$$

where Δx is horizontal distance (positive in the up-hill direction), $|g| = 9.8\text{ m}\cdot\text{s}^{-2}$ is gravitational acceleration magnitude, $\Delta T = T_p - T_e$ is temperature difference between the air near and far from the slope, T_p is temperature of the warm near-mountain air, T_e is temperature of the cooler environmental air, and α is the mountain slope angle. Use absolute temperature in the denominator of the equation above.

The horizontal pressure difference across the anabatic flow is very small compared to the vertical pressure difference of air in hydrostatic balance. However, the horizontal pressure difference occurs across a short horizontal distance (tens of meters), yielding a modest pressure gradient that drives a measurable anabatic wind.

The portion of this pressure-gradient force in the along-slope direction (s) is $F_{sPG} = F_{xPG} \cdot \cos(\alpha)$, as can be seen from Fig. 17.8a. Combining this with the previous equation, and using the trigonometric identity $\tan(\alpha) \cdot \cos(\alpha) = \sin(\alpha)$, gives:

$$\frac{F_{sPG}}{m} = |g| \frac{\Delta T}{T_e} \cdot \sin(\alpha) \quad (17.6)$$

But recall from the vertical equation of motion that the vertical buoyancy force is $F_{zB}/m = |g| \cdot (\Delta T/T_e)$. Thus, eq. (17.6) can also be interpreted as the component of vertical buoyancy force in the up-slope direction (s), as can be seen from Fig. 17.8b.

FOCUS • Anabatic Slope Flow

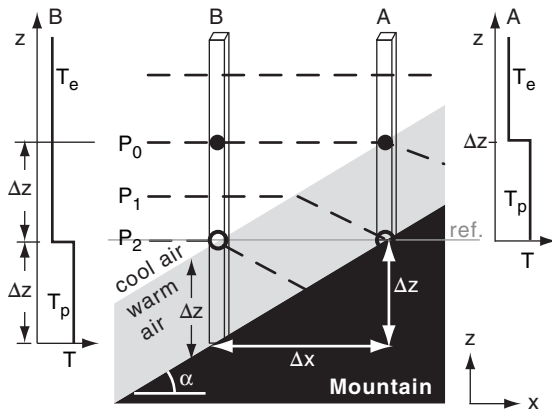

Fig. 17.b. Dashed lines are isobars. Soundings at left and right correspond to columns of air B and A.

Derivation of Horizontal Pressure Gradient

Consider an idealized situation of isothermal environmental air of temperature T_e and warmer near-mountain air (shaded grey) of temperature T_p with uniform vertical depth Δz , as sketched in Fig. 17.b. Consider two air columns: A and B. If a reference height *ref* is set at the base of column A (thin grey line), then place column B such that the same *ref* height is at the top of the warm-air layer.

For both columns A and B, start at the same pressure (P_0 , at the solid black dots in Fig. 17.b). As you descend distance Δz , the pressure P increase depends on air temperature T , as given by the hypsometric equation (from Chapter 1):

$$\ln(P) = \ln(P_0) + \frac{\Delta z}{a \cdot T} \tag{1}$$

where $a = \mathfrak{R}_d/|g| = 29.3 \text{ m/K}$. Thus, the $\ln(P)$ increases linearly with decreasing altitude (Fig. 17.c).

In column B, the temperature is uniformly cool between the solid black dot and the reference height, so pressure increases rapidly as you descend (Fig. 17.c). However, in column A, the temperature is uniformly

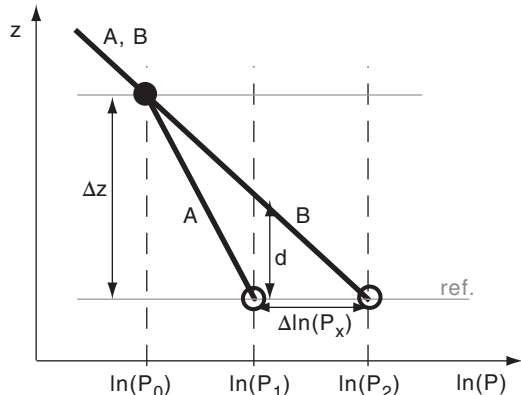

Fig. 17.c. Change of pressure with height, as given by the hypsometric equation for cool air in column B and warm air in column A. (not to scale)

(continues in next column)

FOCUS • Anabatic (continuation)

warmer, so the pressure doesn't increase as fast. By the time you have descended distance Δz from the black dot to the reference height, the pressure in the cold air has increased to P_2 , but in the warm air has increased a smaller amount to P_1 . Thus, at the reference height, there is a horizontal pressure difference $\Delta P = P_2 - P_1$ pointing toward the mountain slope.

To quantify this effect, start with the hypsometric equation, separately for columns A and B:

$$\text{Col. B at ref.: } \ln(P_2) = \ln(P_0) + \Delta z/(a \cdot T_e)$$

$$\text{Col. A at ref.: } \ln(P_1) = \ln(P_0) + \Delta z/(a \cdot T_p)$$

where $a = \mathfrak{R}_d/|g| = 29.3 \text{ m/K}$ from Chapter 1.

Subtract equation A from B

$$\ln(P_2) - \ln(P_1) = \frac{\Delta z}{a} \cdot \left(\frac{1}{T_e} - \frac{1}{T_p} \right)$$

Create a common denominator in the parentheses, and combine the $\ln()$ terms:

$$\ln\left(\frac{P_2}{P_1}\right) = \frac{\Delta z}{a} \cdot \left(\frac{T_p - T_e}{T_e \cdot T_p} \right)$$

Take the exponential of both sides, solve for P_1 :

$$P_1 = P_2 \cdot \exp\left(-\frac{\Delta z}{a} \cdot \frac{\Delta T}{T_e^2}\right)$$

where $\Delta T = T_p - T_e$, and where $T_e^2 \approx T_e \cdot T_p$ because both are absolute temperatures. Next, subtract P_2 from both sides, and let $\Delta P = P_1 - P_2$ be the pressure change in the positive x -direction at the reference height:

$$\Delta P = -P_2 \cdot \left[1 - \exp\left(-\frac{\Delta z}{a} \cdot \frac{\Delta T}{T_e^2}\right) \right]$$

But $\exp(-y) \approx 1 - y + y^2/2 - \dots$. Thus, the pressure decrease along the *ref.* height from B to A is

$$\Delta P \approx -P_B \cdot \left[\frac{\Delta z}{a} \cdot \frac{\Delta T}{T_e^2} \right] \tag{2}$$

Expanding a and using the ideal gas law gives:

$$-\frac{\Delta P}{\rho} \approx |g| \cdot \Delta z \cdot \frac{\Delta T}{T_e}$$

Divide both sides by Δx to give the horizontal pressure-gradient force per unit mass $F_{x \text{ PG}}/m$:

$$\frac{F_{x \text{ PG}}}{m} = -\frac{1}{\rho} \frac{\Delta P}{\Delta x} = |g| \cdot \frac{\Delta T}{T_e} \cdot \frac{\Delta z}{\Delta x}$$

Substituting $\Delta z/\Delta x = \tan(\alpha)$ gives the desired eq. (17.5), where α is the mountain slope angle.

$$\frac{F_{x \text{ PG}}}{m} = -\frac{1}{\rho} \frac{\Delta P}{\Delta x} = |g| \frac{\Delta T}{T_e} \cdot \tan(\alpha) \tag{17.5}$$

Also, in Fig. 17.c, $d = z(P_1 \text{ at B}) - z(P_1 \text{ at A})$ is the deflection distance of the near-mountain end of isobar P_1 in Fig. 17.b.

Solved Example

For the scenario in the previous solved example, suppose a steady-state is reached where the only two forces are buoyancy and drag. Find the anabatic wind speed, assuming an anabatic flow depth of 50 m and drag coefficient of 0.05.

Solution

Given: buoyancy term = 0.085 m·s⁻² from previous solved example. $C_D = 0.05$, $\Delta z = 50\text{m}$

Find: $U_s = ? \text{ m/s}$

Solve eq. (17.7) for U_s , considering only buoyancy and drag terms:

$$U_s = [(\Delta z/C_D) \cdot \text{buoyancy term}]^{1/2}$$

$$= [((50\text{m})/(0.05)) \cdot (0.085 \text{ m}\cdot\text{s}^{-2})]^{1/2} = \underline{9.2 \text{ m/s}}$$

Check: Units OK. Magnitude too large.

Discussion: In real anabatic flows, the temperature excess (5°C in this example) exists only close to the ground, and decreases to near zero by 50 to 100 m away from the mountain slope. If we had applied eq. (17.7) over the 5 m depth of the temperature excess, then a more-realistic answer of 2.9 m/s is found.

A better approach is to use the average temperature excess over the depth of the anabatic flow, not the maximum temperature excess measured close to the mountain slope.

Turbulence is strong during convective conditions such as during anabatic winds, which increases the turbulent drag against the ground.

To forecast the speed of the upslope flow, apply the equation of horizontal motion to a sloping surface and use the approximation above:

$$\frac{\Delta U_s}{\Delta t} = -U_s \frac{\Delta U_s}{\Delta s} - V \frac{\Delta U_s}{\Delta y} + |g| \frac{\Delta \theta_v}{T_{ve}} \sin(\alpha) + f_c \cdot V - C_D \frac{U_s^2}{\Delta z} \tag{17.7}$$

tendency advection buoyancy Coriolis drag

where U_s is along-slope (up- or down-slope) flow, V is across-slope flow, $\Delta \theta_v$ is virtual potential temperature difference between the slope-flow air and the environment (where $\Delta \theta_v = \Delta \theta = \Delta T$ for dry air), T_v is absolute virtual temperature, $f_c = 2\Omega \cdot \sin(\text{latitude})$ is the Coriolis parameter, $2\Omega = 1.458423 \times 10^{-4} \text{ s}^{-1}$, C_D is a drag coefficient against the ground, and Δz is the vertical depth of the slope flow.

Katabatic Wind

During anticyclonic conditions of calm or light synoptic-scale winds at night, air adjacent to a cold mountain slope can become colder than the surrounding air. This cold, dense air flows downhill under the influence of gravity (buoyancy), and is called a **katabatic wind** (Fig. 17.9). It can also form in the daytime over snow- or ice-covered slopes.

The katabatic wind is shallowest at the top of the slope, and increases in thickness and speed further downhill. Typical depths are 10 to 100 m, where the depth is roughly 5% of the vertical drop distance from the hill top. Typical speeds are 3 to 8 m/s. Katabatic flows are shallower and less turbulent than anabatic flows.

Equation (17.7) also applies for katabatic flows, but with negative $\Delta \theta_v$. A horizontal pressure gradient drives the katabatic wind, but with hydrostatic air pressure increasing near the slope due to the cold dense air. Namely, isobars bend upward near the mountain during katabatic flows (Fig. 17.9).

The virtual potential temperature in a katabatic flow is generally coldest at the ground, and smoothly increases with height (Fig. 17.9). For the difference $\Delta \theta_v = (\theta_{vp} - \theta_{ve})$, use the average temperature in the katabatic flow θ_{vp} minus the environmental temperature at the same altitude θ_{ve} .

If there were no friction against the surface, then the fastest downslope winds would be where the air is the coldest; namely, closest to the ground. However, winds closest to the ground are slowed due to turbulent drag, leaving a nose of fast winds just above ground level (Fig. 17.9).

In Antarctica where downslope distances are hundreds of kilometers, the katabatic wind speeds are 3 to 20 m/s with extreme cases up to 50 m/s, and durations are many days. These attributes are sufficiently large that Coriolis force turns the equilibrium wind direction 30 to 50° left of the fall line.

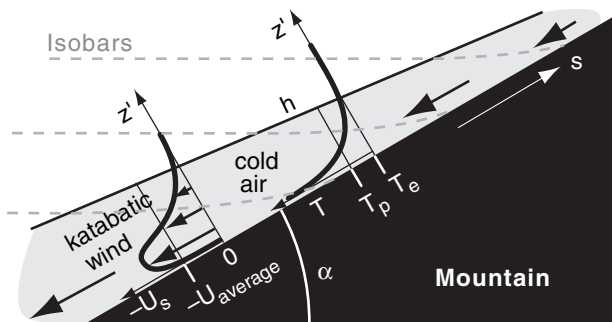

Figure 17.9
Katabatic winds (shaded light gray). Superimposed (thick black lines) are the along-slope wind-speed profile (U_s vs. z') and temperature profile (T vs z'), where z' is normal to the surface s . T_p is the average temperature in the katabatic-flow air, and T_e is the ambient environmental temperature just outside of the katabatic flow. The katabatic wind is indicated with the large arrows. Isobars (dashed grey lines) tilt upward in the cold air.

However, for most smaller valleys and slopes you can neglect Coriolis force and the V -wind, allowing eq. (17.7) to be solved for some steady-state situations, as shown next.

Initially the wind (averaged over the depth of the katabatic flow) is influenced mostly by buoyancy and advection. It accelerates with distance s downslope:

$$|U_{average}| = \left[g \cdot \frac{\Delta\theta_v}{T_{ve}} \cdot s \cdot \sin(\alpha) \right]^{1/2} \quad (17.8)$$

where $|g| = 9.8 \text{ m}\cdot\text{s}^{-2}$, T_{ve} is absolute temperature in the environment at the height of interest, α is the mountain slope angle, and s is distance downslope.

The average katabatic wind eventually approaches an equilibrium where drag balances buoyancy:

$$|U_{eq}| = \left[g \cdot \frac{\Delta\theta_v}{T_{ve}} \cdot \frac{h}{C_D} \cdot \sin(\alpha) \right]^{1/2} \quad (17.9)$$

where C_D is the total drag against both the ground and against the slower air aloft, and h is depth of the katabatic flow.

Along-valley Winds

Katabatic and anabatic winds are part of larger circulations in the valley.

Night

At night, the katabatic winds from the bottom of the slopes drain into the valley, where they start to accumulate. This pool of cold air is often stratified like a layer cake, with the coldest air at the bottom and less-cold air on top. Katabatic winds that start higher on the slope often do not travel all the way to the valley bottom (Fig. 17.10). Instead, they either spread out at an altitude where they have the same buoyancy as the stratified pool in the valley, or they end in a turbulent eddy higher above the valley floor. This leads to a relatively mild **thermal belt** of air at the mid to upper portions of the valley walls — a good place for vineyards and orchards because of fewer frost days.

Meanwhile, the cold pool of air in the valley bottom flows along the valley axis in the same direction that a stream of water would flow. As this cold air drains out of the valley onto the lowlands, it is known as a **mountain wind**. This is part of an **along-valley circulation**. A weak return flow aloft (not drawn), called the **anti-mountain wind**, flows up-valley, and is the other part of this along-valley circulation.

Solved Example (§)

Air adjacent to a 10° slope averages 10°C cooler over its 20 m depth than the surrounding air of virtual temperature 10°C . Find and plot the wind speed vs. downslope distance, and the equilibrium speed. $C_D = 0.005$.

Solution

Given: $\Delta\theta_v = -10^\circ\text{C}$, $T_{ve} = 283 \text{ K}$, $\alpha = 10^\circ$, $C_D = 0.005$
 Find: U (m/s) vs. x (km), where $s \approx x$.

Use eq. (17.9) to find final equilibrium value:

$$|U_{eq}| = \left[\frac{(9.8 \text{ m}\cdot\text{s}^{-2}) \cdot (-10^\circ\text{C}) \cdot (20 \text{ m})}{283 \text{ K} \cdot 0.005} \cdot \sin(10^\circ) \right]^{1/2}$$

$$|U_{eq}| = \underline{15.5 \text{ m/s}}$$

Use eq. (17.8) for the initial variation.

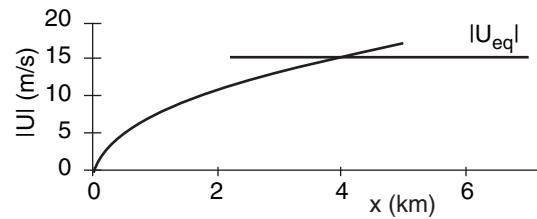

Check: Units OK. Physics OK.

Discussion: Although these two curves cross, the complete solution to eq. (17.7) smoothly transitions from the initial curve to the final equilibrium value.

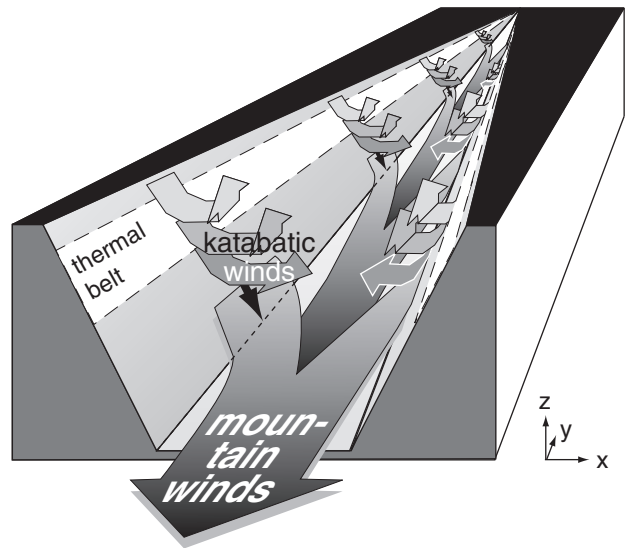

Figure 17.10

Katabatic winds are cross-valley flows that merge into the along-valley mountain winds draining down valley. Relatively warm air can exist in the “thermal belt” regions.

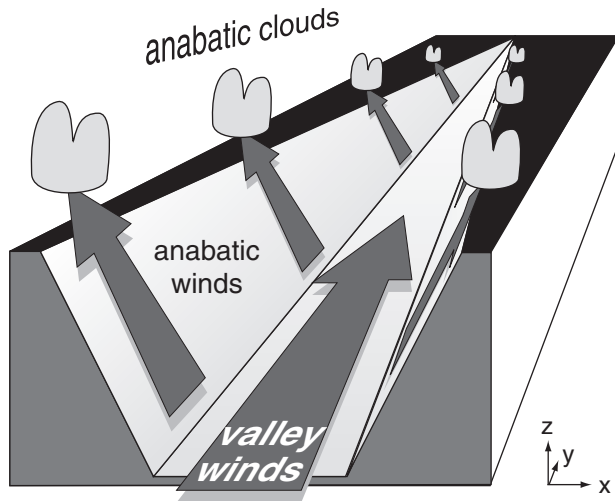

Figure 17.11
Anabatic winds are warm upslope flows that are resupplied with air by valley winds flowing upstream.

FOCUS • On Naming Local Winds

Local winds are often named by where they come from. Winds from the mountains are called mountain winds. Winds from the valley are called valley winds. A breeze from the sea is called a sea-breeze. The opposite is a land breeze.

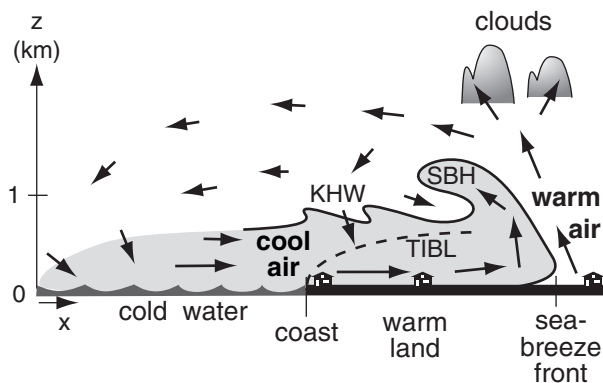

Figure 17.12
Vertical cross section through a sea-breeze circulation. KHW = Kelvin-Helmholtz waves. SBH = sea-breeze head. TIBL = thermal internal boundary layer.

Day

During anabatic conditions, there is often a weak **cross-valley horizontal circulation** (not drawn) from the tops of the anabatic updrafts back toward the center of the valley. Some of this air sinks (**subsides**) over the valley center, and helps trap air pollutants in the valley.

During daytime, the upslope anabatic winds along the valley walls remove air from the valley floor. This lowers the pressure very slightly near the valley floor, which creates a pressure gradient that draws in replacement air from lower in the valley. These upstream flowing winds are called **valley winds** (Fig. 17.11), and are part of an **along-valley circulation**. A weak return flow aloft (heading down valley; not drawn in Fig. 17.11) is called the **anti-valley wind**.

Transitions

Because the sun angle relative to the mountain slope determines the solar heating rate of that slope, the anabatic winds on one side of the valley are often stronger than on the other. At low sun angles near sunrise or sunset, the sunny side of the valley might have anabatic winds while the shady side might have katabatic winds.

Sea breeze

A **sea breeze** is a shallow cool wind that blows onshore (from sea to land) during daytime (Fig. 17.12). It occurs in large-scale high-pressure regions of weak or calm geostrophic wind under mostly clear skies. Similar flows called **lake breezes** form along lake shorelines, and **inland sea breezes** form along boundaries between adjacent land regions with different land-use characteristics (e.g., irrigated fields of crops adjacent to drier land with less vegetation).

The sea breeze is caused by a 5 °C or greater temperature difference between the sun-heated warm land and the cooler water. It is a surface manifestation of a thermally driven mesoscale circulation called the **sea-breeze circulation**, which often includes a weak return flow aloft from land to sea.

For warm air over land, the hypsometric equation states that hydrostatic pressure does not decrease as rapidly with increasing height as it does in the cooler air over the sea (Fig. 17.13). This creates a pressure gradient aloft between higher pressure over land and lower pressure over the sea, which initiates a wind aloft. This wind moves air molecules from over land to over sea, causing surface pressure over the warm land to decrease because fewer total molecules in the warm-air column cause less weight of air at the base of the column. Similarly, the surface pressure over the water increases due to mol-

ecules added to the cool-air column. This creates a pressure gradient near the surface that drives the bottom portion of the sea-breeze circulation. Such **hydrostatic thermal circulations** were explained in the Global Circulation chapter.

A **sea-breeze front** marks the leading edge of the advancing cool marine air and behaves similarly to a weak advancing cold front or a thunderstorm gust front. If the updraft ahead of the front is humid enough, a line of cumulus clouds can form along the front, which can grow into a line of thunderstorms if the atmosphere is convectively unstable.

The raised portion of cool air immediately behind the front, called the **sea-breeze head**, is analogous to the head at the leading edge of a gust front. The sea-breeze head is roughly twice as thick as the subsequent portion of the **feeder** cool onshore flow (which is 0.5 to 1 km thick). The top of the sea-breeze head often curls back in a large horizontal roll eddy over warmer air from aloft.

Vertical wind shear at the density interface between the low-level sea breeze and the return flow aloft can create **Kelvin-Helmholtz (KH) waves**. These breaking waves in the air have wavelength of 0.5 to 1 km. The KH waves increase turbulent drag on the sea breeze by entraining low-momentum air from above the interface. A slowly subsiding return flow occurs over water and completes the circulation as the air is again cooled as it blows landward over the cold water.

As the cool marine air flows over the land, a **thermal internal boundary layer (TIBL)** forms just above the ground (Fig. 17.12). The TIBL grows in depth z_i with the square root of distance x from the shore as the marine air is modified by the heat flux F_H (in kinematic units K·m/s) from the underlying warm ground:

$$z_i = \left[\frac{2 \cdot F_H}{\gamma \cdot M} \cdot x \right]^{1/2} \quad (17.10)$$

where $\gamma = \Delta\theta/\Delta z$ is the gradient of potential temperature in the air just before reaching the coast, and M is the wind speed.

In early morning, the sea-breeze circulation does not extend very far from the coast, but progresses further over land and water as the day progresses. Advancing cold air behind the sea-breeze front behaves somewhat like a **density current** or **gravity current** in which a dense fluid spreads out horizontally beneath a less dense fluid. When this is simulated in water tanks, the speed M_{SBF} of advance of the sea-breeze front, is

$$M_{SBF} = k \cdot \sqrt{|g| \cdot \frac{\Delta\theta_v}{T_v} \cdot d} \quad (17.11)$$

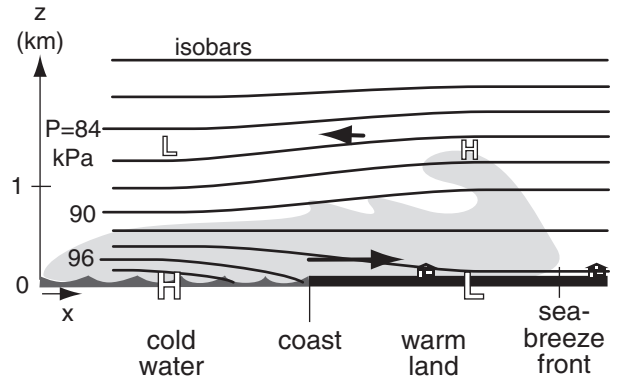

Figure 17.13

Vertical cross section through a sea-breeze circulation, showing isobars. H and L at any one altitude indicate relatively higher or lower pressure. The horizontal pressure gradient is greatly exaggerated in this illustration. Thick arrows show the coast-normal component of horizontal winds.

Solved Example

What horizontal pressure difference is needed in the bottom part of the sea-breeze circulation to drive an onshore wind that accelerates from 0 to 6 m/s in 6 h?

Solution

Given: $\Delta M/\Delta t = (6 \text{ m/s})/(6 \text{ h}) = 0.000278 \text{ m}\cdot\text{s}^{-2}$
 Find: $\Delta P/\Delta x = ? \text{ kPa/km}$

Neglect all other terms in the horiz. eq. of motion:

$$\Delta M/\Delta t = -(1/\rho) \cdot \Delta P/\Delta x \quad (10.23a)$$

Assume air density is $\rho = 1.225 \text{ kg/m}^3$ at sea level.

Solve for $\Delta P/\Delta x$:

$$\begin{aligned} \Delta P/\Delta x &= -\rho \cdot (\Delta M/\Delta t) = -(1.225 \text{ kg/m}^3) \cdot (0.000278 \text{ m}\cdot\text{s}^{-2}) \\ &= -0.00034 \text{ kg}\cdot\text{m}^{-1}\cdot\text{s}^{-2}/\text{m} = -0.00034 \text{ Pa/m} \\ &= \underline{\underline{-0.00034 \text{ kPa/km}}} \end{aligned}$$

Check: Units OK. Magnitude OK.

Discussion: Only a small pressure gradient is needed to drive a sea breeze.

Solved Example

For a surface kinematic heat flux of 0.2 K m/s, wind speed of 5 m/s, and $\gamma = 3\text{K/km}$, find the TIBL depth 5 km from shore.

Solution

Given: $F_H = 0.2 \text{ K}\cdot\text{m/s}$, $M = 5 \text{ m/s}$, $\gamma = 3\text{K/km}$, $x = 5 \text{ km}$
 Find: $z_i = ? \text{ m}$

Use eq. (17.10):

$$\begin{aligned} z_i &= [2 \cdot (0.2 \text{ K}\cdot\text{m/s}) \cdot (5 \text{ km}) / \{(3 \text{ K/km}) \cdot (5 \text{ m/s})\}]^{1/2} \\ &= \underline{\underline{0.365 \text{ km}}} \end{aligned}$$

Check: Units OK. Magnitude reasonable.

Discussion: Above this height, the air still feels the marine influence, and not the warmer land.

Solved Example

Marine-air of thickness 500 m and virtual temperature 16°C is advancing over land. The displaced continental-air virtual temperature is 20°C. Find the sea-breeze front speed, and the sea-breeze wind speed.

Solution

Given: $\Delta\theta_v = \Delta T_v = 20 - 16^\circ\text{C} = 4^\circ\text{C}$, $d = 500$ m

$$T_{v \text{ average}} = (16 + 20^\circ\text{C})/2 = 18^\circ\text{C} = 291\text{K}$$

Find: $M_{SBF} = ?$ m/s, $M = ?$ m/s

For speed-of-advance of the front, use eq. (17.11):

$$M_{SBF} = (0.62) \cdot [(9.8\text{m}\cdot\text{s}^{-2}) \cdot (4\text{K}) \cdot (500\text{m}) / (291\text{K})]^{1/2} \\ = \mathbf{5.1 \text{ m/s}}$$

For the sea-breeze wind speed, use eq. (17.12):

$$M = 1.15 \cdot (5.1\text{m/s}) = \mathbf{5.9 \text{ m/s}}$$

Check: Units OK. Magnitude OK.

Discussion: Because the sea-breeze circulation extends 20 to 250 km over the sea, mariners used these reliable breezes to sail north-south along the Atlantic coasts of Europe and Africa centuries ago. Upon reaching the latitude of the easterly trade winds in the tropical global circulation, they then sailed west towards the Americas. Upon reaching the Americas, they again used the sea-breezes to sail north and south along the East Coasts of North and South America. For the return trip to Europe, they sailed in the mid-latitude westerlies. Thus, by using both local sea-breeze winds and the global circulation, they achieved an effective commercial trade route.

Solved Example

Assuming calm synoptic conditions (i.e., no large-scale winds that oppose or enhance the sea-breeze), what maximum distance inland would a sea-breeze propagate. Use data from the previous solved example, for a latitude of 45°N.

Solution:

Given: $M_{SBF} = 5.1$ m/s from previous example.

$$\text{latitude} = 45^\circ\text{N.}$$

Find: $L = ?$ km

First, find the Coriolis parameter:

$$f_c = (1.458 \times 10^{-4} \text{ s}^{-1}) \cdot \sin(45^\circ) = 1.03 \times 10^{-4} \text{ s}^{-1}$$

Use eq. (17.13):

$$L = (5.1 \text{ m/s}) / [(7.27 \times 10^{-5} \text{ s}^{-1})^2 - (1.03 \times 10^{-4} \text{ s}^{-1})^2]^{1/2} \\ = \mathbf{70 \text{ km}}$$

Check: Units OK. Magnitude reasonable.

Discussion: At 30° latitude the denominator of eq. (17.13) is zero, causing $L = \infty$. But this is physically unreasonable. Thus, we expect eq. (17.13) to not be reliable at latitudes near 30°.

where $\Delta\theta_v$ is the virtual potential temperature difference between the cool marine sea-breeze air and the warmer air over land that is being displaced, T_v is an absolute average virtual temperature, $|g| = 9.8 \text{ m}\cdot\text{s}^{-2}$ is gravitational acceleration magnitude, d is depth of the density current, and constant $k \approx 0.62$.

When fully developed, surface (10 m height) wind speeds in the marine, inflow portion of the sea breeze at the coast are 1 to 10 m/s with typical values of 6 m/s. The relationship between sea-breeze wind speed M at the coast and speed of the sea-breeze front is:

$$M \approx 1.15 \cdot M_{SBF} \quad (17.12)$$

The sea-breeze front can advance $L = 10$ to 200 km inland by the end of the day, although typical advances are $L = 20$ to 60 km unless inhibited by mountains or by opposing synoptic-scale winds. Even without mountain barriers, the sea breeze will eventually turn away from its advance due to Coriolis force. For latitudes $\neq 30^\circ$, L is roughly

$$L \approx \frac{M_{SBF}}{|\omega^2 - f_c^2|^{1/2}} \quad (17.13)$$

where M_{SBF} is given by the previous equation, $\omega = 2\pi/\text{day} = 7.27 \times 10^{-5} \text{ s}^{-1}$ is the frequency of the daily heating/cooling cycle, and $f_c = (1.458 \times 10^{-4} \text{ s}^{-1}) \cdot \sin(\text{latitude})$ is the Coriolis parameter. As the front advances, prefrontal waves may cause wind shifts ahead of the front.

At the end of the day, the sea-breeze circulation dissipates and a weaker, reverse circulation called the **land-breeze** forms in response to the nighttime cooling of the land surface relative to the sea. Sometimes, the now-disconnected sea-breeze front from late afternoon continues to advance farther inland during the night as a **bore** (the front of dense fluid advancing under less-dense fluid; also described as a propagating solitary wave with characteristics similar to the **hydraulic jump**). In Australia, such a bore and its associated cloud along the wave crest are known as the **Morning Glory**.

In the vertical cross section normal to the coastline (as in Fig. 17.12), the surface wind oscillates back and forth between onshore and offshore, reversing directions during the morning and evening hours. The Coriolis force induces an oscillating along-shore wind component that lags the onshore-offshore component by 6 h (or 1/4 of a daily cycle). Hence, the horizontal wind vector rotates throughout the course of the day. Rotation is clockwise in the northern hemisphere and counterclockwise in the southern hemisphere.

The idealized sea-breeze hodograph has an elliptical shape (Fig. 17.14). For example, along a me-

ridional coastline with the ocean to the west in the Northern Hemisphere, the diurnal component of the surface wind tends to be westerly (onshore) during the mid-day, northerly (alongshore) during the evening, easterly near midnight, and southerly (alongshore) near sunrise.

The sea-breeze wind and the mean (24 h average) synoptic-scale surface wind are additive. If the synoptic-scale wind in the above example is blowing, say, from the north, the surface wind speed will tend to be higher around sunset when the mean wind and the diurnal component are in the same direction, than around sunrise when they oppose each other.

Many coasts have complex shaped coastlines with bays or mountains, resulting in a myriad of interactions between local flows that distort the sea breeze and create regions of enhanced convergence and divergence. The sea breeze can also interact with boundary-layer thermals, and urban circulations, causing complex dispersion of pollutants emitted near the shore. If the onshore synoptic-scale geostrophic wind is too strong, only a TIBL develops with no sea-breeze circulation.

In regions such as the west coast of the Americas, where major mountain ranges lie within a few hundred kilometers of the coast, sea breezes and terrain-induced winds appear in combination.

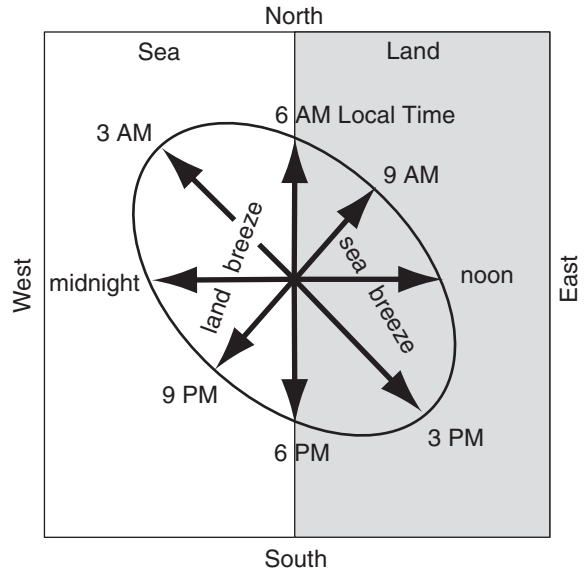

Figure 17.14
Idealized hodograph of surface ($z = 10$ m) wind vectors during a diurnal cycle for a sea breeze. Assumes Northern Hemisphere latitude of Europe, and fair-weather anticyclonic conditions of light to calm large-scale winds. (In this hodograph, compass directions show the direction toward which the wind blows. Also, the vectors are for different times, not different altitudes.)

OPEN-CHANNEL HYDRAULICS

Sometimes a dense cold-air layer lies under a less-dense warmer layer, with a relatively sharp temperature discontinuity ($\Delta T = \Delta\theta$) between the two layers (Fig. 17.15a and b). This temperature jump marks the **density interface** between the two layers. Examples of such a **two-layer system** include arctic air advancing behind a cold front and sliding under warmer air, cold gust fronts from thunderstorms, and cool marine air moving inland under warmer continental air.

These two-layer systems behave similarly to water in an **open channel** — a two layer system of dense water under less-dense air. Hence, you can apply **hydraulics** (applications of liquid flow based on its mechanical properties) to the atmosphere, for cases where air compressibility is not significant.

Sometimes the cold air can be stably stratified (Figs. 17.15c & d) as idealized here with constant lapse rate, where $\Delta\theta/\Delta z = \Delta T/\Delta z + \Gamma_d$, using the dry adiabatic lapse rate $\Gamma_d = 9.8$ °C/km. You can use modified hydraulic theory for these cases.

Hydraulic theory depends on the speed of waves on the interface between cold and warm air.

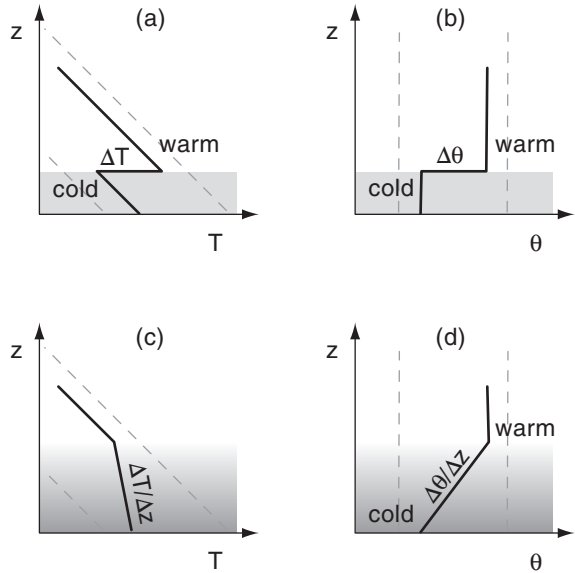

Figure 17.15
Idealized stratification situations in the atmosphere. The dashed lines indicate dry adiabats (lines of constant potential temperature θ) (a) and (b) are two ways of plotting the same situation: two-layers each having uniform potential temperature θ , and with a temperature jump between them. (c) and (d) both show a different situation: a linear change of T with height (i.e., constant stratification) instead of a temperature jump.

Because hydraulics depends on density, it is more accurate to use virtual temperature instead of temperature, to include the effect of humidity on air density. Namely, use T_v instead of T , use ΔT_v instead of ΔT , and $\Delta\theta_v$ instead of $\Delta\theta$.

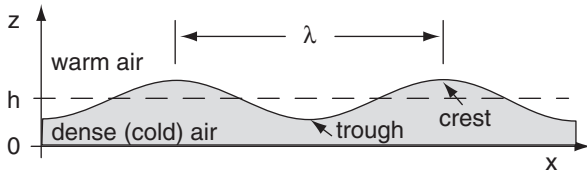

Figure 17.16
Sketch of waves on the interface between cold and warm air layers. λ is wavelength, and h is average depth of cold air.

Solved Example

For a two-layer air system with 5°C virtual potential temperature difference across the interface and a bottom-layer depth of 20 m, find the intrinsic group speed, and compare it to the speed of a water wave.

Solution

Given: $\Delta\theta_v = 5^\circ\text{C} = 5\text{K}$, $h = 20\text{ m}$. Assume $T_v = 283\text{ K}$
Find: $c_g = ?\text{ m/s}$, for air and for water

For a 2-layer air system, use eqs. (17.15 & 17.16):
 $c_g = c_o = [(9.8\text{ m}\cdot\text{s}^{-2})\cdot(5\text{K})\cdot(20\text{m})/(283\text{K})]^{1/2} = \mathbf{1.86\text{ m/s}}$

For water under air, use eq. (17.14 & 17.16):
 $c_g = c_o = [(9.8\text{ m}\cdot\text{s}^{-2})\cdot(20\text{m})]^{1/2} = \mathbf{14\text{ m/s}}$

Check: Units OK. Magnitude OK.

Discussion: Atmospheric waves travel much slower than channel or ocean waves, and have much longer wavelengths. This is because of the reduced gravity $|g'|$ for air, compared to the full gravity $|g|$ for water.

Solved Example

Find the internal-wave horizontal group speed in air for a constant virtual potential-temperature gradient of 5°C across a stable-layer depth of 20 m.

Solution

Given: $\Delta\theta_v = 5^\circ\text{C} = 5\text{K}$, $\Delta z = h = 20\text{ m}$. Let $T_v = 283\text{ K}$
Find: $u_g = ?\text{ m/s}$

Use eq. (17.17):
 $u_g = [(9.8\text{ m}\cdot\text{s}^{-2})\cdot(5\text{K})/(283\text{K} \cdot 20\text{m})]^{1/2} \cdot (20\text{m}) = \mathbf{1.86\text{ m/s}}$

Check: Units OK. Magnitude OK.

Discussion: For the example here with $\Delta z = h$, the equation for u_g in a stably-stratified fluid is identical to the equation for c_g in a two layer system. This is one of the reasons why we can often use hydraulics methods for a stably-stratified atmosphere.

Wave Speed

Waves (vertical oscillations that propagate horizontally on the density interface) can exist in air (Fig. 17.16), and behave similarly to water waves. For hydraulics, if water in a channel is shallow, then long-wavelength waves on the water surface travel at the intrinsic “shallow-water” **phase speed** c_o of:

$$c_o = \sqrt{|g| \cdot h} \tag{17.14}$$

where $|g| = 9.8\text{ m/s}^2$ is gravitational acceleration magnitude, and h is average water depth. **Phase speed** is the speed of propagation of any wave crest. **Intrinsic** means relative to the mean fluid motion. **Absolute** means relative to the ground.

For a two-layer air system, the **reduced gravity** $|g'| = |g| \cdot \Delta\theta_v / T_v$ accounts for the cold-air buoyancy relative to the warmer air. For a shallow bottom layer, the resulting intrinsic phase speed of **surface waves** on the interface between the cold- and warm-air layers is:

$$c_o = \sqrt{|g'| \cdot h} = \left(|g| \cdot \frac{\Delta\theta_v}{T_v} \cdot h \right)^{1/2} \tag{17.15}$$

where $\Delta\theta_v$ is the virtual potential temperature jump between the two air layers, T_v is an average absolute virtual temperature (in Kelvin), h is the depth of the cold layer of air, and $|g| = 9.8\text{ m}\cdot\text{s}^{-2}$ is gravitational acceleration magnitude.

The speed that wave energy travels through a fluid is the **group speed** c_g . Group speed is the speed that hydraulic information can travel relative to the mean flow velocity, and it determines how the upstream flow reacts to downstream flow changes. For a two-layer system with bottom-layer depth less than 1/20 the wavelength, the group speed equals the phase speed

$$c_g = c_o \tag{17.16}$$

For a statically-stable atmospheric system with constant lapse rate, there is no surface (no interface) on which the waves can ride. Instead, **internal waves** can exist that propagate both horizontally and vertically inside the statically-stable region. Internal waves reflect from solid surfaces such as the ground, and from statically neutral layers.

For internal waves, the horizontal component of group velocity u_g depends on both vertical and horizontal wavelength λ . To simplify this complicated situation, focus on infinitely-long waves in the horizontal (which propagate the fastest in the horizontal), and focus on a wave for which the vertical wavelength is proportional to the depth h of the statically stable layer of air. Thus:

$$u_g = N_{BV} \cdot h = \left(\frac{|g|}{T_v} \cdot \frac{\Delta\theta_v}{\Delta z} \right)^{1/2} \cdot h \tag{17.17}$$

where N_{BV} is the Brunt-Väisälä frequency, and $\Delta\theta_v/\Delta z$ is the vertical gradient of virtual potential temperature (a measure of static-stability strength).

Froude Number - Part 1

The ratio of the fluid speed (M) to the wave group velocity (c_g , the speed that energy and information travels) is called the **Froude number** Fr .

$$Fr = M / c_g \quad (17.18)$$

At least three different Froude numbers can be defined, depending on the static stability and the flow situation. We will call these Fr_1 , Fr_2 , and Fr_3 , the last of which will be introduced in a later section.

For surface (interfacial) waves in an idealized atmospheric two-layer system where $c_g = c_o = (|g'| \cdot h)^{1/2}$, the Froude number is $Fr_1 = M/c_o$:

$$Fr_1 = \frac{M}{\left(|g| \cdot \frac{\Delta\theta_v}{T_v} \cdot h\right)^{1/2}} \quad (17.19)$$

where h is the depth of the bottom (cold) air layer, $\Delta\theta_v$ is the virtual potential temperature jump between the two air layers, T_v is an average absolute virtual temperature (in Kelvins), and $|g| = 9.8 \text{ m}\cdot\text{s}^{-2}$ is gravitational acceleration magnitude.

For the other situation of a statically stable region supporting internal waves, the Froude number is $Fr_2 = M/u_g$:

$$Fr_2 = \frac{M}{\left(\frac{|g|}{T_v} \cdot \frac{\Delta\theta_v}{\Delta z}\right)^{1/2} \cdot h} \quad (17.20)$$

The nature of the flow is classified by the value of the Froude number:

- **subcritical (tranquil)** for $Fr < 1$
- **critical** for $Fr = 1$
- **supercritical (rapid)** for $Fr > 1$

For subcritical flow, waves and information travel upstream faster than the fluid is flowing downstream, thus allowing the upstream flow to “feel” the effect of both upstream conditions and downstream conditions such as flow constrictions. For supercritical flow, the fluid is moving so fast that no information can travel upstream (relative to a fixed location); hence, the upstream fluid does not “feel” the effects of downstream flow constrictions until it arrives at the constriction. For airflow, the words (upwind, downwind) can be used instead of (upstream, downstream).

Solved Example

For a two-layer air system with 5°C virtual potential temperature difference across the interface and a bottom-layer depth of 20 m, find the Froude number if the average flow speed is 5 m/s. Discuss whether the flow is critical.

Solution

Given: $\Delta\theta_v = 5^\circ\text{C} = 5\text{K}$, $h = 20 \text{ m}$. $M = 5 \text{ m/s}$.

Assume $T_v = 283 \text{ K}$

Find: $Fr_1 = ?$ (dimensionless)

For a 2-layer air system, use eq. (17.19):

$$Fr_1 = (5 \text{ m/s}) / [(9.8 \text{ m}\cdot\text{s}^{-2}) \cdot (5\text{K}) \cdot (20\text{m}) / (283\text{K})]^{1/2}$$

$$= (5 \text{ m/s}) / (1.86 \text{ m/s}) = \mathbf{2.69}$$

Check: Units OK. Magnitude OK.

Discussion: This flow is supercritical. Hence, the air blows the wave downwind faster than it can propagate upwind against the mean flow.

Solved Example

For a smooth virtual potential-temperature gradient of 5°C across a stable-layer depth of 20 m, find the Froude number if the average flow speed is 5 m/s. Discuss whether the flow is critical.

Solution

Given: $\Delta\theta_v = 5^\circ\text{C} = 5\text{K}$, $\Delta z = h = 20 \text{ m}$.

Assume $T_v = 283 \text{ K}$

Find: $Fr_2 = ?$ (dimensionless)

Use eq. (17.20). But since $\Delta z = h$, this causes eq. (17.20) to reduce to eq. (17.19). Hence, we get the same answer as in the previous solved example:

$$Fr_2 = \mathbf{2.69}$$

Check: Units OK. Magnitude OK.

Discussion: This flow is also supercritical. Although this example was contrived to give the same virtual potential temperature gradient across the whole fluid depth as before, often this is not the case. So always use eq. (17.20) for a constant stable stratification flow, and don't assume that it always reduces to eq. (17.19).

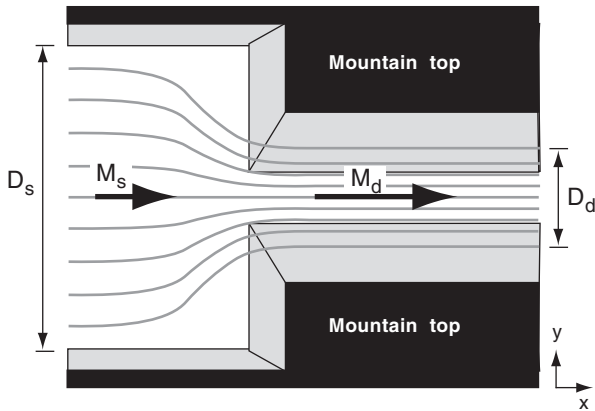

Figure 17.17
Acceleration of air through a constriction. View looking down from above.

Solved Example

If a 20 km wide band of winds of 5 m/s must contract to pass through a 2 km wide gap, what is the wind speed in the gap.

Solution

Given: $D_s = 20 \text{ km}$, $D_d = 2 \text{ km}$, $M_s = 5 \text{ m/s}$.
Find: $M_d = ? \text{ m/s}$

Use eq. (17.23): $M_d = [(20\text{km})/(2\text{km})] \cdot (5\text{m/s}) = \mathbf{50 \text{ m/s}}$

Check: Units OK. Physics OK.

Discussion: The actual winds would be slower, because turbulence would cause significant drag.

Conservation of Air Mass

Consider a layer of well-mixed cold air flowing at speed M_s along a wide valley of width D_s . If it encounters a constriction where the valley width shrinks to D_d (Fig. 17.17), the winds will accelerate to M_d to conserve the amount of air mass flowing. If the depth h of the flow is constant (not a realistic assumption), then **air-mass conservation** gives:

$$\text{mass flowing out} = \text{mass flowing in} \quad (17.21)$$

$$\rho \cdot \text{volume flowing out} = \rho \cdot \text{volume flowing in}$$

$$\rho \cdot M_d \cdot h \cdot D_d = \rho \cdot M_s \cdot h \cdot D_s \quad (17.22)$$

Thus,

$$M_d = \frac{D_s}{D_d} \cdot M_s \quad \bullet(17.23)$$

under the assumptions of negligible changes in air density ρ . Thus, the flow must become faster in the narrower valley.

Similarly, suppose air is flowing downhill through a valley of constant-width D . Cold air of initial speed M_s might accelerate due to gravity to speed M_d further down the slope. Air-mass conservation requires that the depth of the flow h_d in the high speed region be less than the initial depth h_s in the lower-speed region.

$$h_d = \frac{M_s}{M_d} \cdot h_s \quad (17.24)$$

Hydraulic Jump

Consider a layer of cold air flowing supercritically in a channel or valley. If the valley geometry or slope changes at some downstream location and allows wind speed M to decrease to its critical value ($Fr = 1$), there often occurs a sudden increase in flow depth h and a dramatic increase in turbulence. This transition is called a **hydraulic jump**. Downstream of the hydraulic jump, the wind speed is slower and the flow is subcritical.

In Fig. 17.18, you can consider the hydraulic jump as a wave that is trying to propagate upstream. However, the cold air flowing downslope is trying to wash this wave downstream. At the hydraulic jump, the wave speed exactly matches the opposing wind speed, causing the wave to remain stationary relative to the ground.

For example (Fig. 17.18), consider cold air flowing down a mountain slope. It starts slowly, and has $Fr < 1$. As gravity accelerates the air downslope and causes its depth to decrease, the Froude can eventually reach the critical value $Fr = 1$. As the air continues to accelerate downhill the flow can become supercritical ($Fr > 1$). But once this supercritical flow

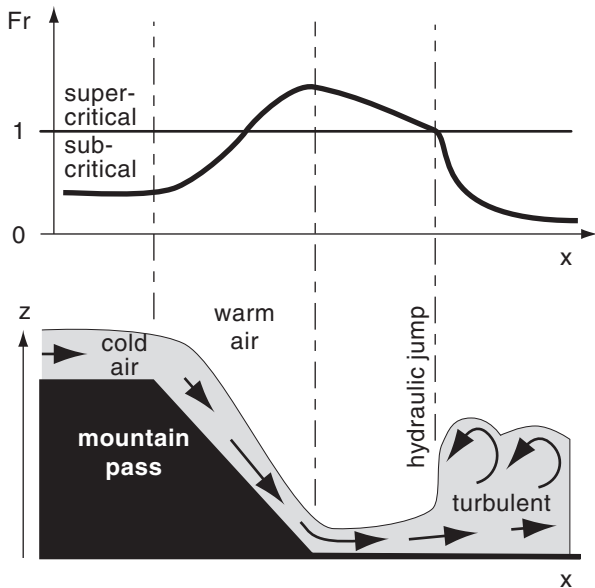

Figure 17.18
Variation of Froude number (Fr) with downwind distance (x), showing a hydraulic jump where the flow changes from supercritical to subcritical.

reaches the bottom of the slope and begins to decelerate due to turbulent drag across the lowland, its velocity can decrease and the flow depth gradually increases. At some point downstream the Froude number again reaches its critical value $Fr = 1$. An hydraulic jump can occur at this point, and turbulent drag increases. If this descending cold air is foggy or polluted, the hydraulic jump can be visible.

GAP WINDS

Basics

During winter in mountainous regions, sometimes the synoptic-scale weather pattern can move very cold air toward a mountain range. The cold air is denser than the warm overlying air, so buoyancy opposes rising motions in the cold air. Thus, the mountain range is a barrier that dams cold air behind it (Fig. 17.20).

However, river valleys, fjords, straits, and passes (Fig. 17.19) are mountain gaps through which the cold air can move as **gap winds** (Fig. 17.20). Gap wind speeds of 5 to 25 m/s have been observed, with gusts to 40 m/s. Temperature jumps at the top of the cold-air layer in the 5 to 10°C range are typical, while extremes of 15°C have been observed. Gap flow depths of 500 m to over 2 km have been observed. In any locale, the citizens often name the gap wind after their town or valley.

The cold airmass dammed on one side of the mountain range often has high surface pressure (H), as explained in the Hydrostatic Thermal Circulation section of the Global Circulation chapter. When synoptic low-pressure centers (L) approach the opposite side of the mountain range, a pressure gradient of order $(0.2 \text{ kPa})/(100 \text{ km})$ forms across the range that can drive the gap wind. Gap winds can also be driven by gravity, as cold air is pulled downslope through a mountain pass.

Divide gap flow into two categories based on the gap geometry: (1) short gaps, and (2) long gaps. Long gaps are ones with a gap width (order of 2 - 20 km) that is much less than the gap length (order of 100 km). Coriolis force is important for flow through long gaps, but is small enough to be negligible in short gaps.

Short-gap Winds

Use open-channel hydraulics for short gaps, and neglect Coriolis force. Although the gap-wind speed could range from subcritical to supercritical, observations suggest that one or more hydraulic jumps (Fig. 17.21) are usually triggered in the supercritical

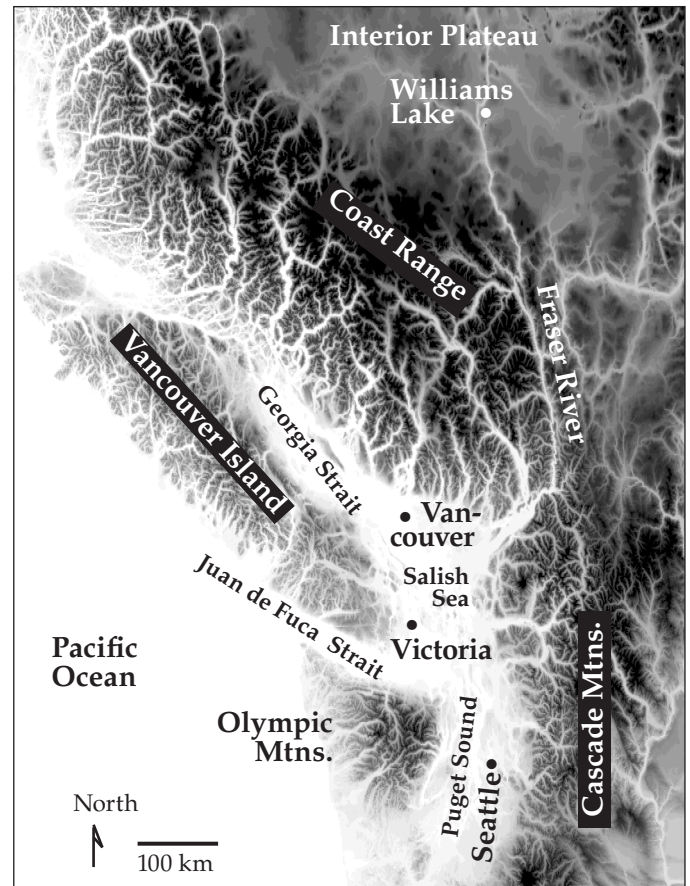

Figure 17.19

Geography of southwestern British Columbia, Canada, and northwestern Washington, USA, illustrating mountain gaps. Higher elevations are shown as darker greys, with the highest peaks 3,000 to 4,000 m above sea level. Ocean and very-low-elevation-land areas are white. Lower-elevation fjords, straits, and river valleys (i.e., gaps) appear as filaments of white or light-grey across the dark-shaded mountain range. In winter, sometimes very cold arctic air can pool in the Interior Plateau northeast of the Coast Mountains.

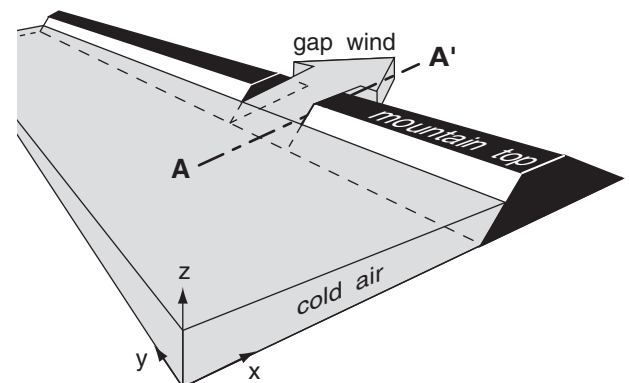

Figure 17.20

Cold air flow through a short gap.

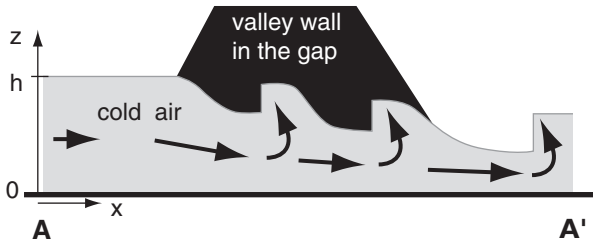

Figure 17.21
Cold air flow through a short gap. Vertical slice inside the gap, along section **A - A'** from the previous figure. A series of 3 hydraulic jumps are shown in this idealization.

Solved Example

Cold winter air of virtual potential temperature -5°C and depth 200 m flows through an irregular short mountain pass. The air above has virtual potential temperature 10°C . Find the max likely wind speed through the short gap.

Solution

Given: $\Delta\theta_v = 15^{\circ}\text{C} = 15\text{K}$, $h = 200\text{ m}$.

Find: $M_{\text{gap max}} = ?\text{ m/s}$

For a 2-layer air system, use eq. (17.25):

$$M_{\text{gap max}} = [(9.8\text{ m}\cdot\text{s}^{-2}) \cdot (15\text{K}) \cdot (200\text{m}) / (267\text{K})]^{1/2} = \underline{10.5\text{ m/s}}$$

Check: Units OK. Magnitude OK.

Discussion: Because of the very strong temperature jump across the top of the cold layer of air and the correspondingly faster wave group speed, faster gap flow speeds are possible. Speeds any faster than this would cause an hydraulic jump, which would increase turbulent drag and slow the wind back to this wind speed.

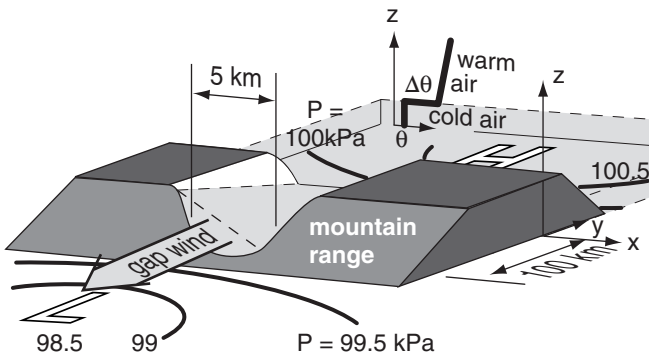

Figure 17.22
Scenario for gap winds in the N. Hemisphere in long valleys, with cold air (light grey) dammed behind a mountain range (dark grey). High pressure (H) is in the cold air, and low pressure (L) is at the opposite side of the mountains. Thick curved lines are sea-level isobars around the synoptic-scale pressure centers. The vertical profile of potential temperature θ is plotted.

regions due to irregularities in the valley shape, or by obstacles. The resulting turbulence in the hydraulic jumps causes extra drag, slowing the wind to its critical value.

The net result is that many gap winds are likely to have maximum speeds nearly equal to their critical value: the speed that gives $Fr = 1$. Using this in the definition of the Froude number allows us to solve for the likely maximum gap wind speed through gaps short enough that Coriolis force is not a factor:

$$M_{\text{gap max}} = \left[|g| \cdot \frac{\Delta\theta_v}{T_v} \cdot h \right]^{1/2} \quad (17.25)$$

Long-gap Winds

For long gaps, examine the horizontal forces (including Coriolis force) that act on the air. Consider a situation where the synoptic-scale isobars are nearly parallel to the axis of the mountain range (Fig. 17.22), causing a pressure gradient across the mountains.

For long narrow valleys this synoptic-scale cross-mountain pressure gradient is unable to push the cold air through the gap directly from high to low pressure, because Coriolis force tends to turn the wind to the right of the pressure gradient. Instead, the cold air inside the gap shifts its position to enable the gap wind, as described next.

Fig. 17.23 idealizes how this wind forms in the N. Hemisphere. Cold air (light grey in Fig. 17.23a) initially at rest in the gap feels the synoptically imposed pressure-gradient force F_{PGs} along the valley axis, and starts moving at speed M (shown with the short dark-grey arrow in Fig. 17.23a') toward the imposed synoptic-scale low pressure (L) on the opposite side of the gap. At this slow speed, both Coriolis force (F_{CF}) and turbulent drag force (F_{TD}) are correspondingly small (Fig. 17.23a'). The sum (black-and-white dotted arrow) of all the force vectors (black) causes the wind to turn slightly toward its right in the N. Hemisphere and to accelerate into the gap.

This turning causes the cold air to “ride up” on the right side of the valley (relative to the flow direction, see Fig. 17.23b). It piles up higher and higher as the gap wind speed M increases. But cold air is denser than warm. Thus slightly higher pressure (small dark-grey H) is under the deeper cold air, and slightly lower pressure (small dark-grey L) is under the shallower cold air. The result is a cross-valley mesoscale pressure-gradient force F_{PGm} per unit mass m (Fig. 17.23b') at the valley floor of:

$$\frac{F_{PGm}}{m} = -\frac{1}{\rho} \cdot \frac{\Delta P_m}{\Delta x} = -|g| \cdot \frac{\Delta\theta_v}{T_v} \cdot \frac{\Delta z}{\Delta x} \quad (17.26)$$

where $\Delta z/\Delta x$ is the cross-valley slope of the top of the cold-air layer, $\Delta P_m/\Delta x$ is the mesoscale pressure gradient across the valley, $\Delta\theta_v$ is the virtual potential temperature difference between the cold and warm air, T_v is an average virtual temperature (Kelvin), $|g| = 9.8 \text{ m}\cdot\text{s}^{-2}$ is the magnitude of gravitational acceleration, and ρ is the average air density.

When this new pressure gradient force is vector-added to the larger drag and Coriolis forces associated with the moderate wind speed M , the resulting vector sum of forces (dotted white-and-black vector; Fig. 17.23b') begins to turn the wind to become almost parallel to the valley axis.

Gap-wind speed M increases further down the valley (Fig. 17.23c and c'), with the gap-wind cold air hugging the right side of the valley. In the along-valley direction (the $-y$ direction in Figs. 17.23), the synoptic pressure gradient force F_{PGs} is often larger

than the opposing turbulent drag force F_{TD} , allowing the air to continue to accelerate along the valley, reaching its maximum speed near the valley exit. The **antitriptic wind** results from a balance of drag and synoptic-scale pressure-gradient forces. Similar gap winds are sometimes observed in the Juan de Fuca Strait (Fig. 17.19), with the fastest gap winds near the west exit region of the strait.

In the cross-valley direction, Coriolis force F_{CF} nearly balances the mesoscale pressure gradient force F_{PGm} . These last two forces define a mesoscale “**gap-geostrophic wind**” speed G_m parallel to the valley axis:

$$G_m = \left| \frac{g}{f_c} \cdot \frac{\Delta\theta_v}{T_v} \cdot \frac{\Delta z}{\Delta x} \right| \quad (17.27)$$

The actual gap wind speeds are of the same order of magnitude as this gap-geostrophic wind.

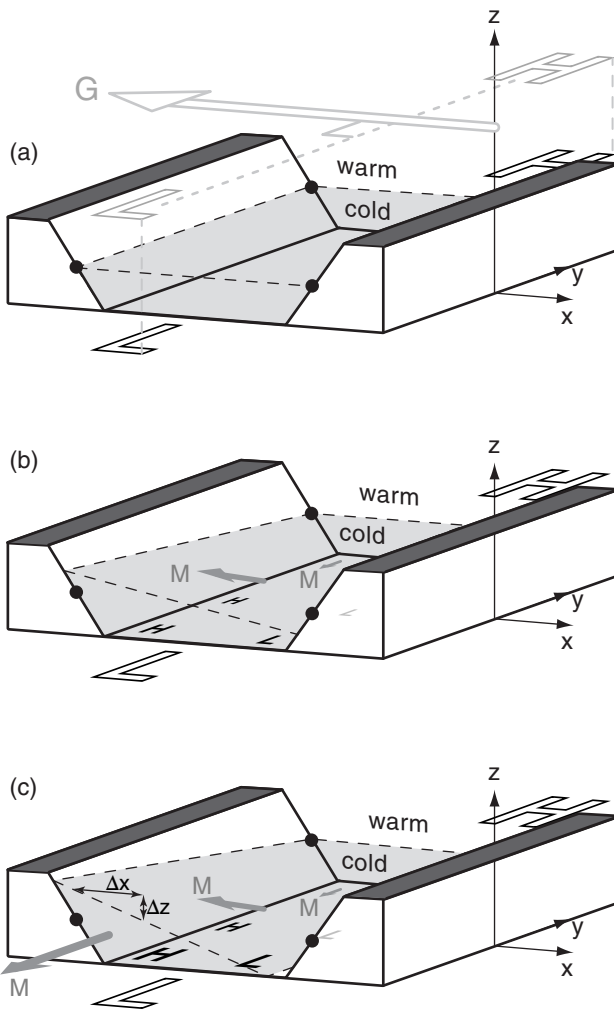
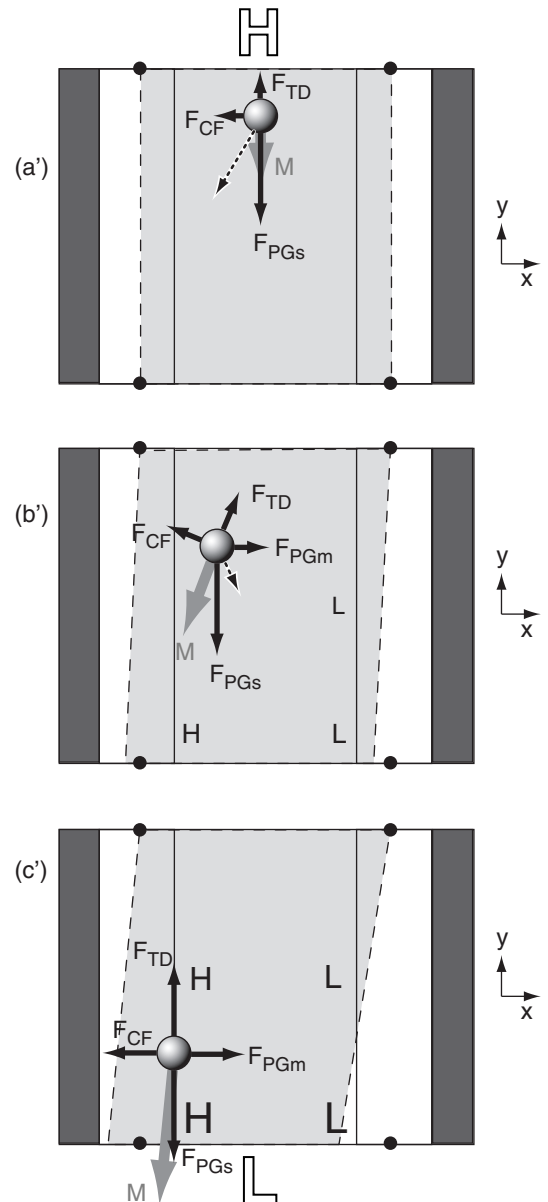

Figure 17.23
An enlargement of just the mountain gap portion of the previous figure. (a)-(c) Oblique view showing evolution of the cold air (light grey) in the gap. (a')-(c') Plan view (looking down from above) showing the corresponding forces acting on a cold air parcel as a gap wind forms (see text for details).



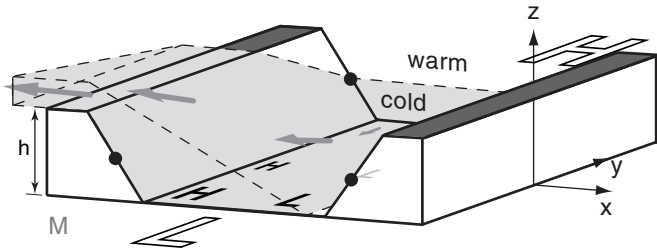

Figure 17.24
Gap winds can overtop the valley side walls if these walls are too low, or if the temperature difference between cold and warm layers of air is too small.

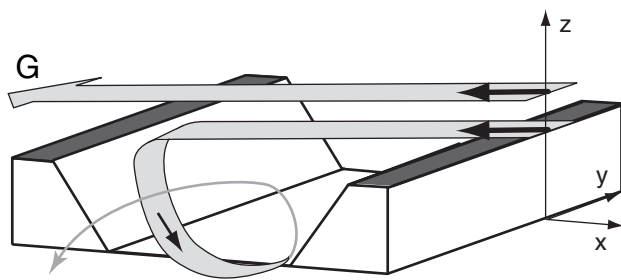

Figure 17.25
Without a layer of cold air near the surface, the cross-valley component of synoptic-scale geostrophic wind can create turbulent corkscrew motions and channeling of wind in the valley.

Solved Example

What long-gap wind speed can be supported in a strait 10 km wide through mountains 0.5 km high? The cold air is 4°C colder than the overlying 292 K air.

Solution

Given: $h = \Delta z = 0.5 \text{ km}$, $\Delta x = 10 \text{ km}$, $\Delta\theta_v = 4^\circ\text{C} = 4 \text{ K}$,
 $T_v = 0.5 \cdot (288\text{K} + 292\text{K}) = 290\text{K}$.

Find: $G_m = ? \text{ m/s}$

Assume: $f_c = 10^{-4} \text{ s}^{-1}$.

Use eq. (17.27):

$$G_m = |(9.8 \text{ m}\cdot\text{s}^{-2} / 10^{-4} \text{ s}^{-1}) \cdot (4\text{K} / 290\text{K}) \cdot (0.5\text{km} / 10\text{km})| = \underline{67 \text{ m/s}}$$

Check: Units OK. Magnitude seems too large.

Discussion: The unrealistically large magnitude might be reached if the strait is infinitely long. But in a finite-length strait, the accelerating air would exit the strait before reaching this theoretical wind speed.

We implicitly assumed that the air was relatively dry, allowing $T_v \approx T$, and $\Delta\theta_v \approx \Delta\theta$. If humidity is larger, then you should be more accurate when calculating virtual temperatures. Also, as the air accelerates within the valley, mass conservation requires that the air depth Δz decreases, thereby limiting the speed according to eq. (17.27).

The synoptic-scale geostrophic wind on either side of the mountain range is nearly equal to the synoptic-scale geostrophic wind well above the mountain (G , in Fig. 17.23a). These synoptic winds are at right angles to the mesoscale gap-geostrophic wind.

The maximum possible gap wind speed is given by the equation above, but with Δz replaced with the height h of the valley walls above the valley floor. If either h or $\Delta\theta_v$ are too small, then some of the cool air can ride far enough up the valley wall to escape over top of the valley walls (Fig. 17.24), and the resulting gap winds are weaker. Gap winds occur more often in winter, when cold valley air causes large $\Delta\theta_v$.

For a case where $\Delta\theta_v$ is near zero (i.e., near-neutral static stability), the synoptic-scale geostrophic wind dominates. The vector component of G along the valley axis can appear within the valley as a **channeled wind** parallel to the valley axis. However, the cross-valley component of G can create strong turbulence in the valley (due to cavity, wake, and mountain-wave effects described later in this chapter). These components combine to create a turbulent corkscrew motion within the valley (Fig. 17.25).

COASTALLY TRAPPED LOW-LEVEL (BARRIER) JETS

Coriolis force is also important in locations such as the eastern Pacific Ocean, where low-altitude wind jets form parallel to the west coast of N. America. The dynamics describing these jets are very similar to the dynamics of long-gap winds.

Consider situations where synoptic-scale low-pressure systems reach the coast of N. America and encounter mountain ranges. Behind the approaching cyclone is cold air, the leading edge of which is the cold front (Fig. 17.26a). The cold air stops advanc-

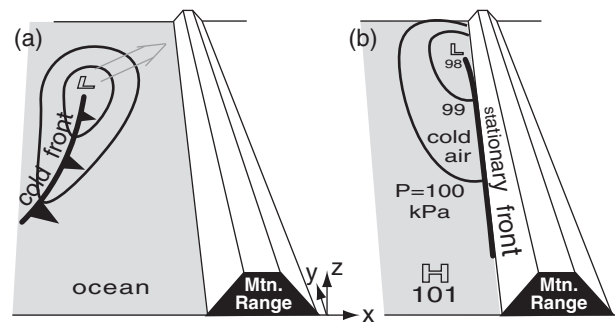

Figure 17.26
(a) Precursor synoptic conditions, as a low L center approaches a coastal mountain (Mtn.) range in the N. Hemisphere. Curved lines are isobars at sea level. (b) Conditions later when the low reaches the coast, favoring coastally trapped low-level jets.

ing eastward when it hits the mountains, causing a stationary front along the ocean side of the mountain range (Fig. 17.26b).

A pressure gradient forms parallel to the mountain range (Fig. 17.26b), between the low (L) center to the north and higher pressure (H) to the south. Fig. 17.27 shows a zoomed view of the resulting situation close to the mountains. The isobars are approximately perpendicular to the mountain-range axis, not parallel as was the case for gap winds.

As the synoptic-scale pressure gradient (PGs) accelerates the cold air from high towards low, Coriolis force (CF) turns this air toward the right (in the N. Hem.) causing the cold air to ride up along the mountain range. This creates a mesoscale pressure gradient (PGm) pointing down the cold-air slope (Fig. 17.28). Eventually an equilibrium is reached where turbulent drag (TD) nearly balances the synoptic pressure-gradient force, and Coriolis force is balanced by the mesoscale pressure gradient.

The end result is a low-altitude cold wind parallel to the coast, just west of the mountain range. The jet-core height is centered about 1/3 of the distance from the ocean (or lowland floor) to the ridge top. Jet core altitudes of 50 to 300 m above sea level have been observed along the west coast of N. America, while altitudes of about 1 km have been observed in California west of the Sierra-Nevada mountain range. Maximum speeds of 10 to 25 m/s have been observed in the jet core.

Width of the coastal jet is on the order of 100 to 150 km. This width is roughly equal to the **Rossby radius of deformation**, λ_R , which is a measure of the upstream region of influence of the mountain range on a flow that is in geostrophic balance. For a cold marine layer of air capped by a strong inversion as sketched in Fig. 17.28, the **external Rossby radius of deformation** is

$$\lambda_R = \frac{\sqrt{|g| \cdot h \cdot \Delta\theta_v / T_v}}{f_c} \quad (17.28)$$

where $|g| = 9.8 \text{ m}\cdot\text{s}^{-2}$ is gravitational acceleration magnitude, h is mountain range height, f_c is the Coriolis parameter, $\Delta\theta_v$ is the jump of virtual potential temperature at the top of the marine air layer, and T_v is an average absolute virtual temperature of the air. For a statically-stable layer of air having a linear increase of potential temperature with height instead of a step discontinuity, an **internal Rossby radius of deformation** is

$$\lambda_R = \frac{N_{BV} \cdot h}{f_c} \quad (17.29)$$

where $N_{BV} = [(|g|/T_v) \cdot \Delta\theta_v/\Delta z]^{1/2}$ is the Brunt-Väisälä frequency.

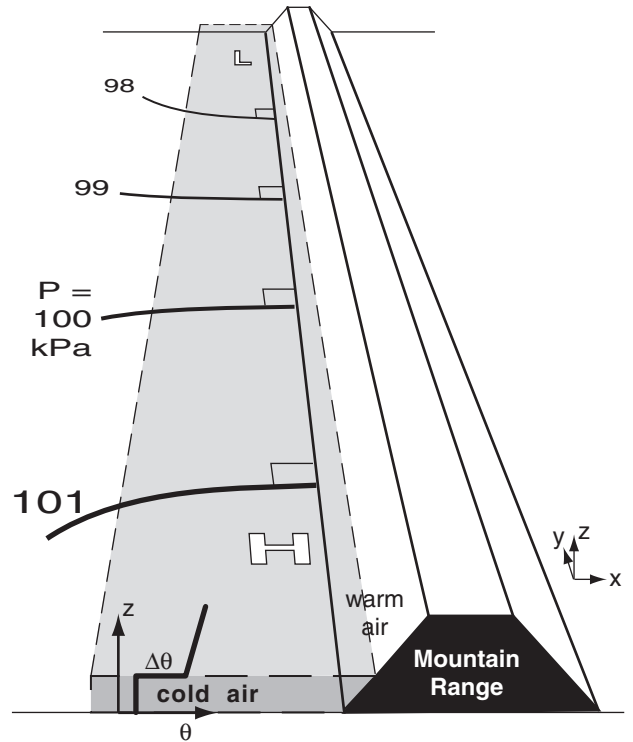

Figure 17.27
Synoptic conditions that favor creation of a mesoscale low-level jet parallel to the coast. Curved lines are isobars, H and L are high and low-pressure centers, and θ is potential temperature.

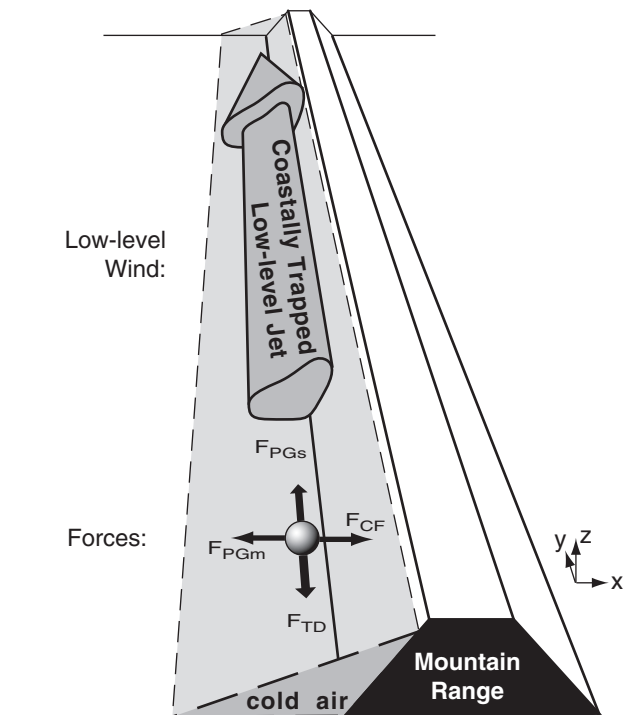

Figure 17.28
Final force (F) balance and cold-air location during a coastally trapped low-level jet (fast winds parallel to the coast). Vertical scale is stretched roughly 100:1 relative to the horizontal scale

Solved Example

The influence of the coast mountains extends how far to the west of the coastline in Fig. 17.28? The cold air has virtual potential temperature 8°C colder than the neighboring warm air. The latitude is such that the Coriolis parameter is 10^{-4} s^{-1} . Mountain height is 2000 m.

Solution

Given: $h = 2000 \text{ m}$, $\Delta\theta_v = 8^\circ\text{C} = 8 \text{ K}$, $f_c = 10^{-4} \text{ s}^{-1}$.
 Find: $\lambda_R = ? \text{ km}$, external Rossby deformation radius

Assume: $|g|/T_v = 0.03333 \text{ m}\cdot\text{s}^{-2}\cdot\text{K}^{-1}$
 The region of influence extends a distance equal to the Rossby deformation radius. Thus, use eq. (17.28):
 $\lambda_R = [(0.03333 \text{ m}\cdot\text{s}^{-2}\cdot\text{K}^{-1}) \cdot (2000 \text{ m}) \cdot (8 \text{ K})]^{1/2} / (10^{-4} \text{ s}^{-1})$
 $= 231,000 \text{ m} = \mathbf{231 \text{ km}}$

Check: Units OK. Magnitude OK.
Discussion: Even before fronts and low-pressure centers hit the coastal mountains, the mountains are already influencing these weather systems hundreds of kilometers offshore.

Solved Example (§)

Find and plot the path of air over a mountain, given: $z_1 = 500 \text{ m}$, $M = 30 \text{ m/s}$, $b = 3$, $\Delta T/\Delta z = -0.005 \text{ K/m}$, $T = 10^\circ\text{C}$, and $T_d = 8^\circ\text{C}$ for the streamline sketched in Fig. 17.29.

Solution

Given: (see above). Thus $T = 283 \text{ K}$
 Find: $N_{BV} = ? \text{ s}^{-1}$, $\lambda = ? \text{ m}$, and plot z vs. x

From the Stability chapter:

$$N_{BV} = \left[\frac{9.8 \text{ m}\cdot\text{s}^{-2}}{283 \text{ K}} \cdot (-0.005 + 0.0098) \right]^{1/2}$$

$$= 0.0129 \text{ s}^{-1}$$

Use eq. (17.30)

$$\lambda = \frac{2\pi \cdot (30 \text{ m/s})}{0.0129 \text{ s}^{-1}} = 14.62 \text{ km}$$

Solve eq. (17.31) on a spreadsheet to get the answer:

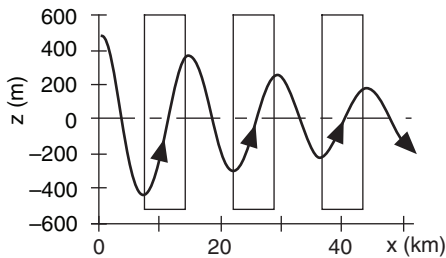

Check: Units OK. Physics OK. Sketch OK.
Discussion: Glider pilots can soar in the updraft portions of the wave, highlighted with white boxes.

MOUNTAIN WAVES

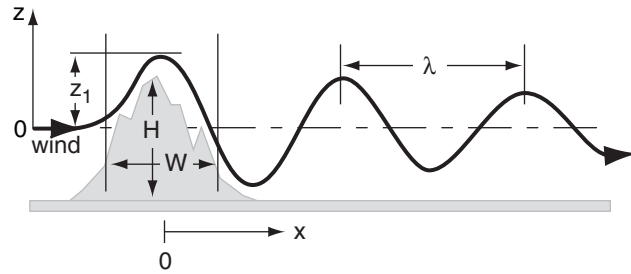

Figure 17.29
 Mountain-wave characteristics.

Natural Wavelength

When statically stable air flows with speed M over a hill or ridge, it is set into oscillation at the Brunt-Väisälä frequency, N_{BV} . The natural wavelength λ is

$$\lambda = \frac{2\pi \cdot M}{N_{BV}} \quad \bullet(17.30)$$

Longer wavelengths occur in stronger winds, or weaker static stabilities.

These waves are known as **mountain waves**, **gravity waves**, **buoyancy waves**, or **lee waves**. They can cause damaging winds, and interesting clouds (see the Cloud chapter).

Friction and turbulence damp the oscillations with time (Fig. 17.29). The resulting path of air is a damped wave:

$$z = z_1 \cdot \exp\left(\frac{-x}{b \cdot \lambda}\right) \cdot \cos\left(\frac{2\pi \cdot x}{\lambda}\right) \quad (17.31)$$

where z is the height of the air above its starting equilibrium height, z_1 is the initial amplitude of the wave (based on height of the mountain), x is distance downwind of the mountain crest, and b is a damping factor. Wave amplitude reduces to $1/e$ at a downwind distance of b wavelengths (that is, $b \cdot \lambda$ is the e-folding distance).

Lenticular Clouds

In the updraft portions of mountain waves, the rising air cools adiabatically. If sufficient moisture is present, clouds can form, called **lenticular clouds**. The first cloud, which forms over the mountain crest, is usually called a **cap cloud** (see Cloud chapter).

The droplet sizes in these clouds are often quite uniform, because of the common residence times of air in the clouds. This creates interesting optical

phenomena such as **corona** and **iridescence** when the sun or moon shines through them (see the Optics chapter).

Knowing the temperature and dew point of air at the starting altitude before blowing over the mountain, a lifting condensation level (LCL) can be calculated using equations from the Moisture chapter. Clouds will form in the crests of those waves for which $z > z_{LCL}$.

Froude Number - Part 2

For individual hills not part of a continuous ridge, some air can flow around the hill rather than over the top. When less air flows over the top, shallower waves form.

The third variety of **Froude Number** Fr_3 is a measure of the ability of waves to form over hills. It is given by

$$Fr_3 = \frac{\lambda}{2 \cdot W} \quad \bullet(17.32)$$

where W is the hill width, and λ is the natural wavelength. Fr_3 is dimensionless.

For strong static stabilities or weak winds, $Fr_3 \ll 1$. The natural wavelength of air is much shorter than the width of the mountain, resulting in only a little air flowing over the top of the hill, with small waves (Fig. 17.30a). If H is the height of the hill (Fig. 17.29), then wave amplitude $z_1 < H/2$ for this case. Most of the air is **blocked** in front of the ridge, or flows around the sides for an isolated hill.

For moderate stabilities where the natural wavelength is nearly equal to twice the hill width, $Fr_3 \approx 1$. The air **resonates** with the terrain, causing very intense waves (Fig. 17.30b). These waves have the greatest chance of forming lenticular clouds, and pose the threat of violent turbulence to aircraft. Extremely fast near-surface winds on the downwind (lee) side of the mountains cause **downslope wind storms** that can blow the roofs off of buildings. Wave amplitude roughly equals half the hill height: $z_1 \approx H/2$. Sometimes rotor circulations and **rotor clouds** will form near the ground under the wave crests (Fig. 17.30b; also see the Cloud chapter).

For weak static stability and strong winds, the natural wavelength is much greater than the hill width, $Fr_3 \gg 1$. Wave amplitude is weak, $z_1 < H/2$. A turbulent **wake** will form downwind of the mountain, sometimes with a **cavity** of reverse flow near the ground (Fig. 17.30c). The cavity and rotor circulations are driven by the wind like a bike chain turning a gear.

For statically neutral conditions, $Fr = \infty$. A large turbulent wake occurs (Fig. 17.30d). These wakes are hazardous to aircraft.

Solved Example (§)

Replot the results from the previous solved example, indicating which waves have lenticular clouds.

Solution

Given: (see previous solved example).

Find: $z_{LCL} = ?$ m.

From the Moisture chapter: $z_{LCL} = a \cdot (T - T_d)$.

$$z_{LCL} = (125\text{m}/^\circ\text{C}) \cdot (10^\circ\text{C} - 8^\circ\text{C}) = \mathbf{250\text{ m}}$$

above the reference streamline altitude. From the sketch below, we find 1 cap cloud and 2 lenticular clouds.

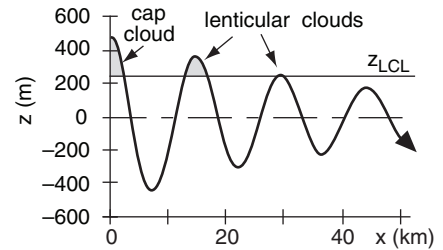

Check: Units OK. Physics OK. Sketch OK.

Discussion: Most clouds are blown with the wind, but **standing-lenticular clouds** are stationary while the wind blows through them!

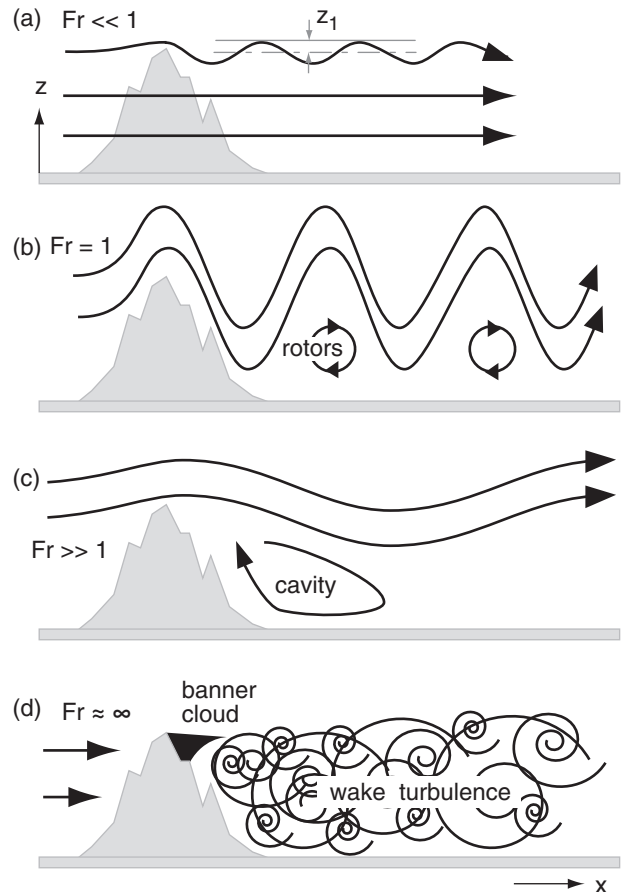

Figure 17.30
Mountain wave behavior vs. Froude number, Fr_3 .

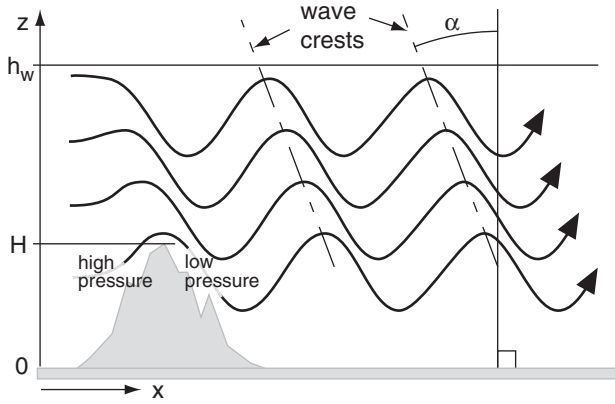

Figure 17.31
Vertical wave propagation, tilting crests, and wave drag.

Solved Example

For $Fr_3 = 0.8$, find the angle of the wave crests and the wave drag force over a hill of height 800 m. The Brunt-Väisälä frequency is 0.01 s^{-1} , and the waves fill the 11 km thick troposphere.

Solution

Given: $Fr_3 = 0.8$, $H = 800 \text{ m}$, $N_{BV} = 0.01 \text{ s}^{-1}$.
Find: $\alpha = ?^\circ$, $F_{xWD}/m = ? \text{ m}\cdot\text{s}^{-2}$

Use eq. (17.33): $\alpha = \cos^{-1}(0.8) = \underline{36.9^\circ}$
Use eq. (17.34):

$$\frac{F_{xWD}}{m} = -\frac{[(800\text{m}) \cdot (0.01\text{s}^{-1})]^2}{8 \cdot (11,000\text{m})} \cdot 0.8 \cdot [1 - (0.8)^2]^{1/2}$$

$$= \underline{3.5 \times 10^{-4} \text{ m}\cdot\text{s}^{-2}}$$

Check: Units OK. Physics OK.

Discussion: This is of the same order of magnitude as the other forces in the equations of motion.

Solved Example

For a natural wavelength of 10 km and a hill width of 15 km, describe the type of waves.

Solution

Given: $\lambda = 10 \text{ km}$, $W = 15 \text{ km}$.
Find: $Fr = ?$ (dimensionless)

Use eq. (17.32): $Fr_3 = (10\text{km})/[2 \cdot (15\text{km})] = \underline{0.333}$

Check: Units OK. Magnitude OK.

Discussion: Waves as in Fig. 17.30a form off the top of the hill, because $Fr_3 < 1$. Some air also flows around sides of hill.

Mountain-wave Drag

For $Fr_3 < 1$, wave crests tilt upwind with increasing altitude (Fig. 17.31). The angle α of tilt relative to vertical is

$$\cos(\alpha) = Fr_3 \tag{17.33}$$

For this situation, slightly lower pressure develops on the lee side of the hill, and higher pressure on the windward side. This pressure gradient opposes the mean wind, and is called wave drag. Such wave drag adds to the skin drag. The **wave drag (WD)** force per unit mass near the ground is:

$$\frac{F_{xWD}}{m} = -\frac{H^2 \cdot N_{BV}^2}{8 \cdot h_w} \cdot Fr_3 \cdot [1 - Fr_3^2]^{1/2} \tag{17.34}$$

where h_w is the depth of air containing waves.

Not surprisingly, higher hills cause greater wave drag. The whole layer of air containing these waves feels the wave drag, not just the bottom of this layer that touches the mountain.

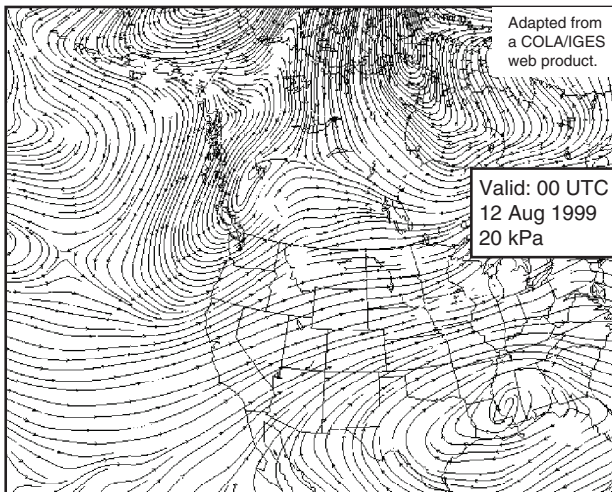

Figure 17.32
Streamlines near the tropopause, over N. America.

STREAMLINES, STREAKLINES, AND TRAJECTORIES

Streamlines are conceptual lines that are everywhere parallel to the flow at some instant (i.e., a snapshot). This is an Eulerian point of view. Fig. 17.32 shows an example of streamlines on a weather map. Streamlines never cross each other except where the speed is zero, and the wind never crosses streamlines. Streamlines can start and end anywhere, and can change with time. They are often not straight lines.

Streaklines are lines deposited in the flow during a time interval by continuous emission of a tracer from a fixed point. Examples can be seen in aerial photographs of smoke plumes emitted from smokestacks, or volcanic ash clouds.

Trajectories, also called **path lines**, trace the route traveled by an air parcel during a time interval. This is the Lagrangian point of view. For **stationary** (not changing with time) flow, streamlines, streaklines, and trajectories are identical.

For nonstationary flow (flow that changes with time), there can be significant differences between them. For example, suppose that initially the flow is steady and from the north. Later, the wind suddenly shifts to come from the west.

Fig. 17.33 shows the situation shortly after this wind shift. Streamlines (thin solid lines in this figure) are everywhere from the west in this example. The streakline caused by emission from a smokestack is the thick grey line. The black dashed line shows the path followed by one air parcel in the smoke plume.

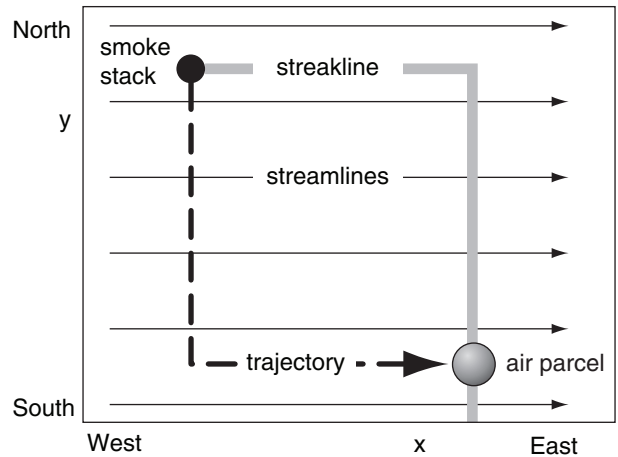

Figure 17.33
Streamlines, streaklines (smoke plumes), and trajectories (path lines) in nonstationary flow.

BERNOULLI'S EQUATION

Principles

Consider a **steady-state** flow (flow that does not change with time), but which can have different velocities at different locations. If we follow an air parcel as it flows along a streamline, its velocity can change as it moves from one location to another. For wind speeds $M \leq 20$ m/s at constant altitude, the air behaves as if it is nearly incompressible (namely, constant density ρ).

Incompressible Flow

For the special case of incompressible, steady-state, **laminar** (nonturbulent) motion with no drag, the equations of motion for an air parcel following a streamline can be simplified into a form known as **Bernoulli's equation**:

$$\frac{1}{2}M^2 + \frac{P}{\rho} + |g| \cdot z = C_B \quad \bullet(17.35)$$

energy: kinetic + flow + potential = constant

where M is the total velocity along the streamline, P is static air pressure, ρ is air density, $|g| = 9.8 \text{ m}\cdot\text{s}^{-2}$ is gravitation acceleration magnitude, and z is height above some reference.

C_B is an arbitrary constant called **Bernoulli's constant** or **Bernoulli's function**. C_B is constant

Science Graffito

"With four parameters I can fit an elephant, and with five I can make him wiggle his trunk."
– John von Neumann (attributed by Enrico Fermi)

Solved Example

Environmental air outside a hurricane has sea-level pressure 100 kPa. Find the rise in sea level at the eye, where sea-level pressure is 90 kPa. Neglect currents and wind waves.

Solution

Given: $P_{env} = 100 \text{ kPa}$, $z_{env} = 0 \text{ m}$, $P_{eye} = 90 \text{ kPa}$, $M \approx 0$
Find: $z_{eye} = ? \text{ m}$, where z is height of sea level.

Consider a streamline in the water at the sea surface.
 $\rho = 1025 \text{ kg/m}^3$ for sea water.

Use **Bernoulli's** eq. (17.35) to find C_B for the environment, then use it for the eye:

$$\text{Env: } 0.5 \cdot (0 \text{ m/s})^2 + (100,000 \text{ Pa}) / (1025 \text{ kg/m}^3) + (9.8 \text{ m/s}^2) \cdot (0 \text{ m}) = C_B = 97.6 \text{ m}^2/\text{s}^2$$

$$\text{Eye: } 0.5 \cdot (0 \text{ m/s})^2 + (90,000 \text{ Pa}) / (1025 \text{ kg/m}^3) + (9.8 \text{ m/s}^2) \cdot (z_{eye}) = C_B = 97.6 \text{ m}^2/\text{s}^2$$

$$z_{eye} = \{ (97.6 \text{ m}^2/\text{s}^2) - [(90,000 \text{ Pa}) / (1025 \text{ kg/m}^3)] \} / (9.8 \text{ m/s}^2) = \mathbf{1.0 \text{ m}}$$

Check: Units OK. Magnitude OK.

Discussion: Such a rise in sea level is a hazard called the **storm-surge**.

BEYOND ALGEBRA • Bernoulli Derivation

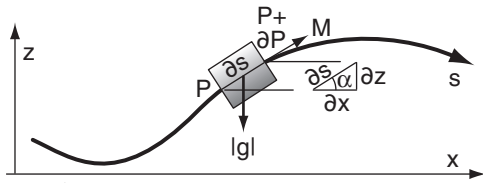

Fig. 17.d. Forces on air parcel following streamline.

To derive Bernoulli’s equation, apply Newton’s second law ($a = F/m$) along a streamline s : Acceleration is the total derivative of wind speed: $a = dM/dt = \partial M/\partial t + M \cdot \partial M/\partial s$. Consider the special case of flow that is steady at any location ($\partial M/\partial t = 0$) even though the flow can be different at different locations ($\partial M/\partial s \neq 0$). Thus

$$M \cdot \partial M/\partial s = F/m$$

The forces per unit mass F/m acting on a fluid parcel along the direction of the streamline are pressure-gradient force and the component of gravity along the streamline [$|g| \cdot \sin(\alpha) = |g| \cdot \partial z/\partial s$]:

$$M \cdot \partial M/\partial s = -(1/\rho) \cdot \partial P/\partial s - |g| \cdot \partial z/\partial s$$

or

$$(1/2) dM^2 + (1/\rho) \cdot dP + |g| \cdot dz = 0$$

For incompressible flow, $\rho = \text{constant}$. Integrate the equation above to get Bernoulli’s equation:

$$(1/2) M^2 + P/\rho + |g| \cdot z = C_B$$

where C_B is the constant of integration.

This result applies only to steady incompressible flow along a streamline. Do not use it for situations where additional forces are important, such as turbulent drag, or across wind turbines or fans.

along any one streamline, but different streamlines can have different C_B values.

Bernoulli’s equation focuses on **mechanical-energy** conservation along a streamline. The first term on the left is the **kinetic energy** per unit mass. The middle term is the work done on the air (sometimes called **flow energy** per unit mass) that has been stored as pressure. The last term on the left is the **potential energy** per mass. Along any one streamline, energy can be converted from one form to another, provided the sum of these energies is constant.

In hydraulics, the gravity term is given by the change in depth of the water, especially when considering a streamline along the water surface. In meteorology, a similar situation occurs when cold air rises into a warmer environment; namely, it is a dense fluid rising against gravity. However, the gravity force felt by the rising cold air is reduced because of its buoyancy within the surrounding air. To compensate for this, the gravity factor in Bernoulli’s equation can be replaced with a **reduced gravity** $g' = |g| \cdot \Delta\theta_v/T_v$, yielding:

$$\frac{1}{2} M^2 + \frac{P}{\rho} + |g| \frac{\Delta\theta_v}{T_v} \cdot z = C_B \quad \bullet(17.36)$$

where $\Delta\theta_v$ is the virtual potential temperature difference between the warm air aloft and the cold air below, and T_v is absolute virtual air temperature (K). Thus, the gravity term is nonzero when the streamline of interest is surrounded by air of different virtual potential temperature, for air flowing up or down.

To use eq. (17.36), first measure all the terms in the left side of the equation at some initial (or upstream) location in the flow. Call this point 1. Use this to calculate the initial value of C_B . Then, at some downstream location (point 2) along the same streamline use eq. (17.36) again, but with the known value of C_B from point 1. The following equation is an expression of this procedure of equating final to initial flow states:

$$\bullet(17.37)$$

$$\frac{1}{2} M_2^2 + \frac{P_2}{\rho} + |g| \frac{\Delta\theta_v}{T_v} \cdot z_2 = \frac{1}{2} M_1^2 + \frac{P_1}{\rho} + |g| \frac{\Delta\theta_v}{T_v} \cdot z_1$$

Another way to consider eq. (17.36) is if any one or two terms increase in the equation, the other term(s) must decrease so that the sum remains constant. In other words, the sum of changes of all the terms must equal zero:

Solved Example

Cold-air flow speed 10 m/s changes to 2 m/s after passing a hydraulic jump. This air is 10°C colder than the surroundings. How high can the hydraulic-jump jump?

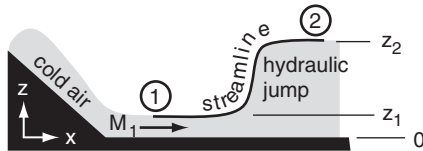

Solution

Given: $M_1 = 10 \text{ m/s}$, $M_2 = 2 \text{ m/s}$, $\Delta T = 10\text{K}$, $z_1 = 0$.
Find: $z_2 = ? \text{ m}$ above the initial z .

Assume: $\Delta\theta_v = \Delta T$ and $|g|/T_v = 0.0333 \text{ m}\cdot\text{s}^{-2}\cdot\text{K}^{-1}$. $P \approx \text{constant}$ on a streamline along the top of the cold air.

Use eq. (17.36), noting that $C_B - P/\rho$ is constant :

- At point 1: $0.5 \cdot (10\text{m/s})^2 + 0 = C_B - P/\rho = 50 \text{ m}^2/\text{s}^2$
 - At 2: $0.5 \cdot (2\text{m/s})^2 + (0.0333\text{m}\cdot\text{s}^{-2}\cdot\text{K}^{-1}) \cdot (10\text{K}) \cdot z_2 = 50 \text{ m}^2/\text{s}^2$
- Solve for z_2 : $z_2 = [M_1^2 - M_2^2] \cdot T_v / (2 \cdot |g| \cdot \Delta\theta_v) = \mathbf{144 \text{ m}}$

Check: Units OK. Magnitude OK.

Discussion: Hydraulic jumps are very turbulent and would dissipate some of the mechanical energy into heat. So the actual jump height would be less.

$$\Delta \left[\frac{1}{2} M^2 \right] + \Delta \left[\frac{P}{\rho} \right] + \Delta \left[|g| \cdot \frac{\Delta \theta_v}{T_v} \cdot z \right] = 0 \quad \bullet (17.38)$$

Caution: $\Delta[(0.5) \cdot M^2] \neq (0.5) \cdot [\Delta M]^2$.

The Bernoulli equations above do NOT work:

- anywhere the flow is turbulent
- behind obstacles that create turbulent wakes or which cause sudden changes in the flow
- at locations of heat input or loss
- at locations of mechanical-energy input (such as a fan) or loss (such as a wind turbine)
- near the ground where drag slows the wind
- where flow speed > 20 m/s
- where density is not approximately constant

Hence, there are many atmospheric situations for which the above equations are too simplistic.

Compressible Flow

For many real atmospheric conditions where winds can be any speed, you should use a more general form of the Bernoulli equation that includes thermal processes.

For an **isothermal** process, the equation becomes:

$$\frac{1}{2} M^2 + \mathfrak{R}_d \cdot T_v \cdot \ln(P) + |g| \frac{\Delta \theta_v}{T_v} \cdot z = C_B \quad (17.39)$$

where $\mathfrak{R}_d = 287 \text{ m}^2 \cdot \text{s}^{-2} \cdot \text{K}^{-1}$ is the ideal gas constant for dry air, and where C_B is constant during the process (i.e., initial C_B = final C_B).

For **adiabatic** (isentropic; no heat transfer) flow, the Bernoulli equation is

$$\frac{1}{2} M^2 + \left(\frac{C_p}{\mathfrak{R}} \right) \frac{P}{\rho} + |g| \frac{\Delta \theta_v}{T_v} \cdot z = C_B \quad (17.40)$$

where C_p is the specific heat at constant pressure, and \mathfrak{R} is the ideal gas constant. For dry air, $C_{pd}/\mathfrak{R}_d = 3.5$ (dimensionless).

Using the ideal gas law, this last equation for adiabatic flow along a streamline becomes

$$\frac{1}{2} M^2 + C_p \cdot T + |g| \frac{\Delta \theta_v}{T_v} \cdot z = C_B \quad \bullet (17.41)$$

kinetic energy + sensible heat + potential energy = constant

where $C_p \cdot T$ is the **enthalpy** (also known as the **sensible heat** in meteorology), and $C_p = 1004 \text{ m}^2 \cdot \text{s}^{-2} \cdot \text{K}^{-1}$ for dry air. In other words:

Solved Example

Wind at constant altitude decelerates from 15 to 10 m/s while passing through a wind turbine. What opposing net pressure difference would have caused the same deceleration in laminar flow?

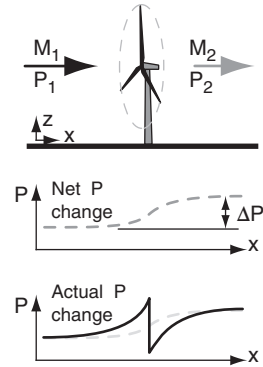

Solution

Given: $\Delta z = 0$,
 $M_1 = 15 \text{ m/s}$, $M_2 = 10 \text{ m/s}$.
 Find: $\Delta P = ? \text{ Pa}$

Assume $\rho = 1 \text{ kg/m}^3 = \text{constant}$.
 Solve eq. (17.38) for ΔP : $\Delta P = -\rho \cdot \Delta[(0.5) \cdot M^2]$
 $\Delta P = -(1 \text{ kg/m}^3) \cdot (0.5) \cdot [(10 \text{ m/s})^2 - (15 \text{ m/s})^2] = \mathbf{62.4 \text{ Pa}}$

Check: Units OK. Magnitude OK.
Discussion: The process of extracting mechanical energy from the wind has the same affect as an opposing pressure difference. This pressure difference is small compared to ambient atmospheric pressure $P = 100,000 \text{ Pa}$.

The actual pressure change across a wind turbine is shown in bottom figure.

Solved Example

Air with pressure 100 kPa is initially at rest. It is accelerated over a flat 0°C snow surface as it is sucked toward a household ventilation system. If the final speed is 10 m/s, what is the air pressure at the fan entrance?

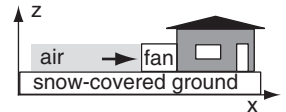

Solution

Given: $P_1 = 100 \text{ kPa}$, $M_1 = 0$, $M_2 = 10 \text{ m/s}$, $\Delta z = 0$.
 Find: $P_2 = ? \text{ kPa}$

Assume the snow keeps their air at constant $T_v = 0^\circ\text{C}$.
 Use eq. (17.39) for an isothermal process:
 $[0.5M_2^2 - 0] + \mathfrak{R}_d T_v \cdot [\ln(P_2) - \ln(P_1)] = 0$
 Use $\ln(a) - \ln(b) = \ln(a/b)$. Then take exp of both sides, and rearrange: $P_2 = P_1 \cdot \exp[-0.5M_2^2 / (\mathfrak{R}_d \cdot T_v)]$
 $P_2 = (100 \text{ kPa}) \cdot \exp[-0.5(10 \text{ m/s})^2 / ((287 \text{ m}^2 \cdot \text{s}^{-2} \cdot \text{K}^{-1}) \cdot (273 \text{ K}))]$
 $= (100 \text{ kPa}) \cdot \exp[-0.000638] = (100 \text{ kPa}) \cdot (0.9994)$
 $= \mathbf{99.94 \text{ kPa}}$

Check: Units OK. Magnitude OK.
Discussion: This decrease of about 0.06 kPa is small compared to ambient $P = 100 \text{ kPa}$. The air-pressure decrease is expected because of the suction caused by the fan.

Solved Example

A short distance behind the engine of a jet aircraft flying in level flight, the exhaust temperature is 400 °C and the jet-blast speed is 200 m/s. After the jet exhaust decelerates to zero, what is the final exhaust air temperature, neglecting conduction & turbulent mixing.

Solution

Given: $M_1 = 200 \text{ m/s}$, $T_1 = 400^\circ\text{C} = 673\text{K}$, $M_2 = 0$, $\Delta z = 0$
 Find: $T_2 = ? \text{ }^\circ\text{C}$. Assume adiabatic process.

Rearrange eq. (17.42): $T_2 = T_1 + M_1^2 / (2C_p)$
 $T_2 = (673\text{K}) + (200\text{m/s})^2 / (2 \cdot 1004 \text{ m}^2\cdot\text{s}^{-2}\cdot\text{K}^{-1})$
 $= 673\text{K} + 19.9\text{K} = 693 \text{ K} = \mathbf{420^\circ\text{C}}$

Check: Units OK. Magnitude OK.

Discussion: Jet exhaust is turbulent and mixes quickly with the cooler ambient air, so it is not appropriate to use Bernoulli's equation. See the "dynamic warming" section later in this chapter for more info.

Solved Example

A 75 kW electric wind machine with a 2.5 m radius fan is used in an orchard to mix air to reduce frost damage on fruit. The fan horizontally accelerates air from 0 to 5 m/s. Find the temperature change across the fan, neglecting mixing with environmental air.

Solution

Given: $Power = 75 \text{ kW} = 75000 \text{ kg}\cdot\text{m}^2\cdot\text{s}^{-3}$, $R = 2.5 \text{ m}$,
 $M_1 = 0$, $M_2 = 5 \text{ m/s}$, $\Delta z = 0$
 Find: $\Delta T = ? \text{ }^\circ\text{C}$

Assume that all the electrical energy used by the fan motor goes into a combination of heat and shaft work.

The mass flow rate through this fan is:
 $\rho \cdot M_2 \cdot \pi R^2 = (1.225 \text{ kg/m}^3) \cdot (5 \text{ m/s}) \cdot \pi (2.5 \text{ m})^2 = 120 \text{ kg/s}$
 Thus: $\Delta q + \Delta SW = Power / (Mass \text{ Flow Rate}) = 624 \text{ m}^2\cdot\text{s}^{-2}$
 Use eq. (17.45): $\Delta T = (1/C_p) \cdot [\Delta q + \Delta SW - 0.5 \cdot (M_2^2 - M_1^2)]$
 $= (1/1004 \text{ m}^2\cdot\text{s}^{-2}\cdot\text{K}^{-1}) \cdot [(624 \text{ m}^2\cdot\text{s}^{-2}) - 0.5 \cdot (5 \text{ m/s})^2]$
 $= 0.61 \text{ K} = \mathbf{0.61^\circ\text{C}}$

Check: Units OK. Magnitude OK.

Discussion: In spite of the large energy consumption of the electric motor, the heating is spread into a very large volume of air that passes through the fan. Hence, the amount of temperature change is small.

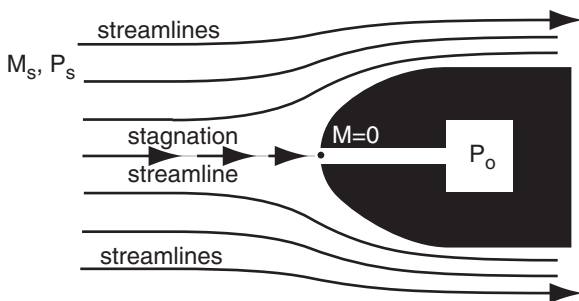

Figure 17.34
 Streamlines, showing stagnation as air approaches the obstacle.

(•17.42)

$$\frac{1}{2} M_2^2 + C_p \cdot T_2 + |g| \frac{\Delta\theta_v}{T_v} \cdot z_2 = \frac{1}{2} M_1^2 + C_p \cdot T_1 + |g| \frac{\Delta\theta_v}{T_v} \cdot z_1$$

where subscript 2 denotes final state, and subscript 1 denotes initial state. Equation (17.41) is also sometimes written as

$$\frac{1}{2} M^2 + C_v \cdot T + \frac{P}{\rho} + |g| \frac{\Delta\theta_v}{T_v} \cdot z = C_B \quad (17.43)$$

energy: kinetic + internal + flow + potential = constant

Again, C_B is constant during the adiabatic process.

Energy Conservation

Because these several previous equations also consider temperature, we cannot call them Bernoulli equations. They are **energy conservation equations** that consider mechanical and thermal energies following a streamline.

If we extend this further into an **energy budget equation**, then we can add the effects of net addition of **thermal energy** (heat per unit mass) Δq via radiation, condensation or evaporation, conduction, combustion, etc. We can also include **shaft work per unit mass** ΔSW done on the air by a fan, or work extracted from the air by a wind turbine.

(17.44)

$$\Delta \left[\frac{1}{2} M^2 \right] + \Delta \left[\frac{P}{\rho} \right] + \Delta [C_v \cdot T] + \Delta \left[|g| \cdot \frac{\Delta\theta_v}{T_v} \cdot z \right] = \Delta q + \Delta SW$$

or

$$\Delta \left[\frac{1}{2} M^2 \right] + \Delta [C_p \cdot T] + \Delta \left[|g| \cdot \frac{\Delta\theta_v}{T_v} \cdot z \right] = \Delta q + \Delta SW \quad \bullet(17.45)$$

Some Applications

Dynamic & Static Pressure & Temperature

Free-stream atmospheric pressure away from any obstacles is called the **static pressure** P_s . Similarly, let T be the free stream (initial) temperature.

When the wind approaches an obstacle, much of the air flows around it, as shown in Fig. 17.34. However, for one streamline that hits the obstacle, air decelerates from an upstream speed of $M_{initial} = M_s$ to an ending speed of $M_{final} = 0$. This ending point is called the **stagnation point**.

As air nears the stagnation point, wind speed decreases, and both the air pressure and temperature increase. The increased pressure is called the **dynamic pressure** P_{dyn} and the increased tempera-

ture is called the **dynamic temperature** T_{dyn} . At the stagnation point where velocity is zero, the final dynamic pressure is called the **stagnation pressure** P_o , and the associated dynamic temperature is given the symbol T_o . Think of subscript "o" as indicating zero wind speed relative to the obstacle.

To find the dynamic effects at stagnation, use the energy conservation equation (17.42) for wind blowing horizontally (i.e., no change in z), and assume a nearly adiabatic process:

$$C_p \cdot T_o = \frac{1}{2} M_s^2 + C_p \cdot T \tag{17.46}$$

Solving for the dynamic temperature T_o gives:

$$T_o = T + \frac{M_s^2}{2 \cdot C_p} \tag{17.47}$$

where $C_p = 1004 \text{ m}^2\text{s}^{-2}\text{K}^{-1}$ for dry air. Eq. (17.47) is valid for subsonic speeds (see Focus box).

This effect is called **dynamic warming** or **dynamic heating**, and must be avoided when deploying thermometers in the wind, because the wind stagnates when it hits the thermometer. As shown in Fig. 17.35, dynamic warming ($\Delta T = T_o - T$) is negligible ($\Delta T \leq 0.2^\circ\text{C}$) for flow speeds of $M_s \leq 20 \text{ m/s}$.

However, for thermometers on an aircraft moving 100 m/s relative to the air, or for stationary thermometers exposed to tornadic winds of $M_s = 100 \text{ m/s}$, the dynamic warming is roughly $\Delta T \approx 5^\circ\text{C}$. For these extreme winds you can correct for dynamic warming by using the dynamic temperature T_o measured by the thermometer, and using the measured wind speed M_s , and then solving eq. (17.47) for free-stream temperature T .

In the Heat chapter is a relationship between temperature and pressure for an adiabatic, compressible process. Using this with the equation above allows us to solve for the **stagnation pressure**:

$$P_o = P_s \cdot \left(\frac{T_o}{T}\right)^{c_p/\mathfrak{R}} \tag{17.48}$$

or

$$P_o = P_s \cdot \left(1 + \frac{0.5 \cdot M_s^2}{C_p \cdot T}\right)^{c_p/\mathfrak{R}} \tag{17.49}$$

where $C_p/\mathfrak{R} \approx C_{pd}/\mathfrak{R}_d = 3.5$ for air, P_s is static (free-stream) pressure, M_s is free-stream wind speed along the streamline, $C_p \approx C_{pd} = 1004 \text{ J}\cdot\text{kg}^{-1}\cdot\text{K}^{-1}$, T is free-stream temperature, and subscript d denotes dry air. Fig. 17.35 shows stagnation-pressure increase.

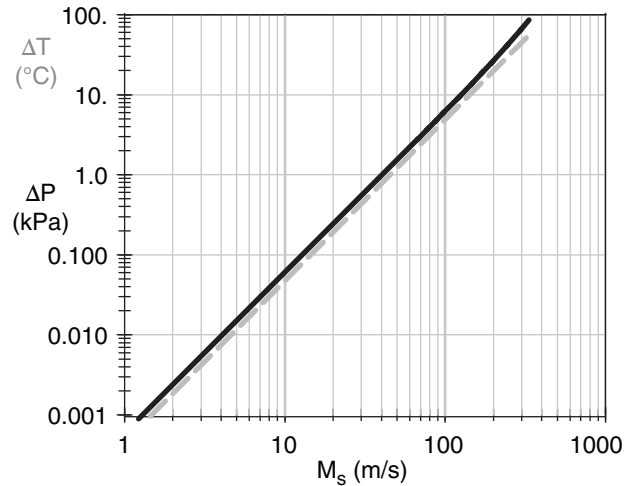

Figure 17.35

Increase in pressure (ΔP , black solid line) and temperature (ΔT , grey dashed line) due to dynamic warming when air of speed M_s hits an obstacle and stagnates. Ambient free-stream conditions for this calculation are $T = 290\text{K}$ and $P_s = 100 \text{ kPa}$, giving a speed of sound of $c = 341 \text{ m/s}$.

Solved Example

Tornadic winds of 100 m/s and 30°C blow into a garage and stagnate. Find stagnation T & P . What net force pushes against a 3 x 5 m garage wall?

Solution

Given: $M_s = 100 \text{ m/s}$, $T = 30^\circ\text{C}$, Wall area $A = 3 \times 5 = 15 \text{ m}^2$
 Find: $F_{net} = ? \text{ N}$. Assume: $\rho = 1.2 \text{ kg/m}^3$, $P = 100 \text{ kPa}$.

Use eq. (17.47):

$$T_o = (30^\circ\text{C}) + [(100\text{m/s})^2 / (2 \cdot 1004\text{m}^2\cdot\text{s}^{-2}\cdot\text{K}^{-1})] = \mathbf{35^\circ\text{C}}$$

Use eq. (17.48):

$$P_o = (100 \text{ kPa}) \cdot [(35+273)/(30+273)]^{3.5} = \mathbf{105.9 \text{ kPa}}$$

Compare with eq. (17.50): $P_o = (100\text{kPa}) + [(0.5 \cdot 1.2\text{kg/m}^3) \cdot (100\text{m/s})^2] \cdot (1 \text{ kPa}/1000\text{Pa}) = \mathbf{106 \text{ kPa}}$

$$F_{net} = \Delta P \cdot A = (6 \text{ kN/m}^2) \cdot (15 \text{ m}^2) = \mathbf{90 \text{ kN}}$$

Check: Units OK. Physics OK.

Discussion: This force is equivalent to the weight of more than 1000 people, and acts on all walls and the roof. It is strong enough to pop the whole roof up off of the house. Then the walls blow out, and the roof falls back down onto the floor.

Hide in the basement. Quickly.

FOCUS • Speed of Sound

The speed c of sound in air is

$$c = [k \cdot \mathfrak{R} \cdot T]^{1/2} \tag{17.42}$$

where $k = C_p/C_v$ is the ratio of specific heats for air, \mathfrak{R} is the ideal gas law constant, and T is absolute temperature. For dry air, the constants are: $k = C_{pd}/C_{vd} = 1.4$, and $\mathfrak{R}_d = 287.053 \text{ (m}^2/\text{s}^2)\cdot\text{K}^{-1}$. Thus, the speed of sound increases with the square root of absolute temperature.

The speed M of any object such as an aircraft or an air parcel can be compared to the speed of sound:

$$Ma = M / c \tag{17.43}$$

where Ma is the dimensionless **Mach number**. Thus, an object moving at Mach 1 is traveling at the speed of sound.

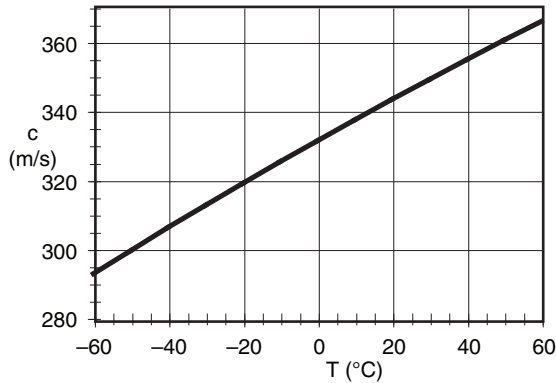

Fig. 17.e. Speed of sound in dry air.

Solved Example

If a 20 km wide band of winds of 5 m/s must contract to pass through a 2 km wide gap, what is the pressure drop in the gap compared to the non-gap flow?

Solution

Given: $D_s = 20 \text{ km}$, $D_d = 2 \text{ km}$, $M_s = 5 \text{ m/s}$.

Find: $M_d = ? \text{ m/s}$.

Assume: $\rho = 1.2 \text{ kg/m}^3$.

Use eq. (17.52):

$$\begin{aligned} \Delta P &= (1.2 \text{ kg}\cdot\text{m}^{-3}/2) \cdot (5 \text{ m/s})^2 \cdot [1 - ((20 \text{ km})/(2 \text{ km}))^2] \\ &= -1485 \text{ kg}\cdot\text{m}^{-1}\cdot\text{s}^{-2} = \mathbf{-1.5 \text{ kPa}} \end{aligned}$$

Check: Units OK. Physics OK.

Discussion: This is a measurable drop in atmospheric pressure. The pressure measured at weather stations in such gaps should be compensated for this venturi effect to calculate the effective static pressure, such as could be used in analyzing weather maps.

For wind speeds of $M_s < 100 \text{ m/s}$, the previous equation is very well approximated by the simple Bernoulli equation for incompressible flow:

$$P_o = P_s + \frac{\rho}{2} M_s^2 \tag{17.50}$$

where ρ is air density. Do not use eq. (17.50) to find dynamic heating when combined with the ideal gas law, because it neglects the large density changes that occur in high-speed flows that stagnate.

The previous 3 equations show that the pressure increase due to stagnation ($\Delta P = P_o - P_s$) is small ($\Delta P < 0.25 \text{ kPa}$) compared to ambient atmospheric pressure ($P_s = 100 \text{ kPa}$) for wind speeds of $M_s < 20 \text{ m/s}$.

Dynamic effects make it difficult to measure static pressure in the wind. When the wind hits the pressure sensor, it decelerates and causes the pressure to increase. For this reason, static pressure instruments are designed to minimize flow deceleration and dynamic errors by having pressure ports (holes) along the sides of the sensor where there is no flow toward or away from the sensor.

Dynamic pressure can be used to measure wind speed. An instrument that does this is the **pitot tube**. Aircraft instruments measure stagnation pressure with the pitot tube facing forward into the flow, and static pressure with another port facing sideways to the flow to minimize dynamic effects. The instrument then computes an “indicated airspeed” from eq. (17.49 or 17.50) using the **pitot – static** pressure difference.

During tornadoes and hurricanes, if strong winds encounter an open garage door or house window, the wind trying to flow into the building causes pressure inside the building to increase dynamically. As is discussed in a solved example, the resulting pressure difference across the roof and walls of the building can cause them to blow out so rapidly that the building appears to explode.

Venturi Effect

Bernoulli’s equation says that if velocity increases in the region of flow constriction, then pressure decreases. This is called the **Venturi effect**.

For gap winds of constant depth, eq. (17.37) can be written as

$$\frac{1}{2} M_s^2 + \frac{P_s}{\rho} = \frac{1}{2} M_d^2 + \frac{P_d}{\rho} \tag{17.51}$$

which can be combined with eq. (17.23) to give the Venturi pressure decrease:

$$P_d - P_s = \frac{\rho}{2} \cdot M_s^2 \cdot \left[1 - \left(\frac{D_s}{D_d} \right)^2 \right] \tag{17.52}$$

Unfortunately, gap flows are often not constant depth, because the temperature inversion that caps these flows are not rigid lids.

DOWNSLOPE WINDS

Consider a wintertime situation of a layer of cold air under warm, with a synoptic weather pattern forcing strong winds toward a mountain range. Flow over ridge-top depends on cold-air depth, and on the strength of the temperature jump between the two layers. If conditions are right, fast winds, generically called **fall winds**, can descend along the lee slope. Sometimes these downslope winds are fast enough to cause significant destruction to buildings, and to affect air and land transportation. **Downslope wind storms** can be caused by mountain waves (previously discussed), bora winds, and foehns.

Bora

If the fast-moving cold air upstream is deeper than the ridge height H (Fig. 17.36), then very fast (hurricane force) cold winds can descend down the lee side. This phenomena is called a **Bora**. The winds accelerate in the constriction between mountain and the overlying inversion, and pressure drops according to the Venturi effect. The lower pressure upsets hydrostatic balance and draws the cold air layer downward, causing fast winds to hug the slope.

The overlying warmer air is also drawn down by this same pressure drop. Because work must be done to lower this warm air against buoyancy, Bernoulli's equation tells us that the Bora winds decelerate slightly on the way down. Once the winds reach the lowland, they are still destructive and much faster than the winds upstream of the mountain, but are slower than the winds at ridge top. See the Solved Example for the application of Bernoulli's equation.

Boras were originally named for the cold fall wind along the Dalmatian coast of Croatia and Bosnia in winter, when cold air from Russia crosses the mountains and descends southwest toward the Adriatic Sea. The name Bora is used generally now for any cold fall wind having similar dynamics.

For situations where the average mountain ridge height is greater than z_i but the mountain pass is lower than z_i , boras can start in the pass (as a gap wind) and continue down the lee slope.

The difference between katabatic and Bora winds is significant. Katabatic winds are driven by the local thermal structure, and form during periods of weak synoptic forcing such as in high-pressure ar-

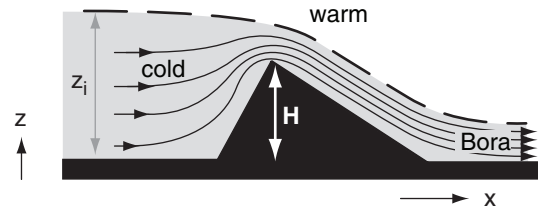

Figure 17.36

Cold Bora winds, during synoptic weather patterns where strong winds are forced toward the ridge from upstream. Thin lines are streamlines. Thick dashed line is a temperature inversion.

Solved Example

For the Bora situation of Fig. 17.36, the inversion of strength 6°C is 1200 m above the upstream lowland. Ridge top is 1000 m above the valley floor. If upstream winds are 10 m/s, find the Bora wind speed in the lee lowlands.

Solution

Given: $H = 1 \text{ km}$, $z_i = 1.2 \text{ km}$, $\Delta\theta_v = 6^\circ\text{C}$,

$M_s = 10 \text{ m/s}$. Assume $|g|/T_v = 0.0333 \text{ m}\cdot\text{s}^{-2}\cdot\text{K}^{-1}$

Find: $M_{Bora} = ? \text{ m/s}$

Volume conservation similar to eq. (17.23) gives ridge top winds M_d :

$$M_d = \frac{z_i}{z_i - H} \cdot M_s = 60 \text{ m/s}$$

Assume Bora thickness = constant = $z_i - H$.

Follow the streamline indicated by the thick dashed line in Fig. 17.36. Assume ending pressure equals starting pressure on this streamline.

Use Bernoulli's eq. (17.37):

$$\left[\frac{1}{2} M^2 + |g| \frac{\Delta\theta_v}{T_v} \cdot z \right]_{\text{ridgetop}} = \left[\frac{1}{2} M^2 + |g| \frac{\Delta\theta_v}{T_v} \cdot z \right]_{\text{Bora}}$$

Combine the above eqs. Along the streamline, $z_{\text{ridgetop}} = z_i$ and $z_{\text{Bora}} = z_i - H$. Thus $\Delta z = H$. Solve for M_{Bora} :

$$M_{Bora} = \left[\left(\frac{z_i}{z_i - H} \right)^2 \cdot M_s^2 - 2 \cdot \frac{|g|}{T_v} \cdot \Delta\theta_v \cdot H \right]^{1/2}$$

Finally, we can plug in the numbers: $M_{Bora} =$

$$\sqrt{\left(\frac{1.2 \text{ km}}{0.2 \text{ km}} \right)^2 \left(10 \frac{\text{m}}{\text{s}} \right)^2 - 2 \cdot \left(0.033 \frac{\text{m}}{\text{s}^2 \cdot \text{K}} \right) \cdot (6\text{K}) \cdot (1000\text{m})}$$

$$= \sqrt{(3600 - 400) \text{ m}^2 \cdot \text{s}^{-1}} = \underline{56.6 \text{ m/s}}$$

Check: Units OK. Physics OK.

Discussion: Winds at ridge top were 60 m/s. Although the Bora winds at the lee lowlands are weaker than ridge top, they are still strong and destructive. Most of the wind speed up was due to volume conservation, with only a minor decrease given by Bernoulli's equation. This decrease is because kinetic energy associated with wind speed must be expended to do work against gravity by moving warm inversion air downward.

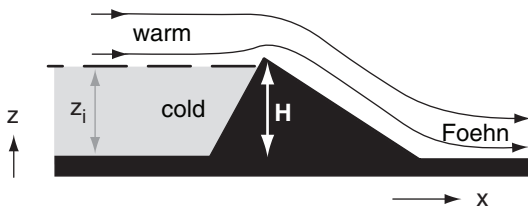

Figure 17.37
 One mechanism for creating warm Foehn winds, given synoptic weather patterns where strong winds are forced toward the mountain ridge from upstream. Thin lines are streamlines. Thick dashed line is a temperature inversion.

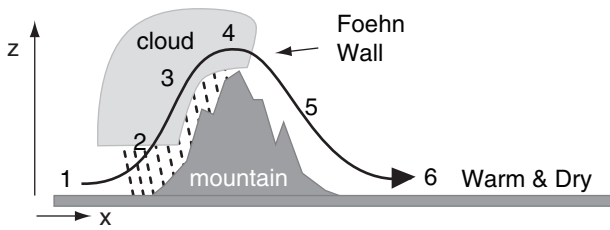

Figure 17.38
 Another mechanism for creating warm Foehn winds, where net heating occurs due to formation and fallout of precipitation (dashed lines). Black curved line shows one streamline.

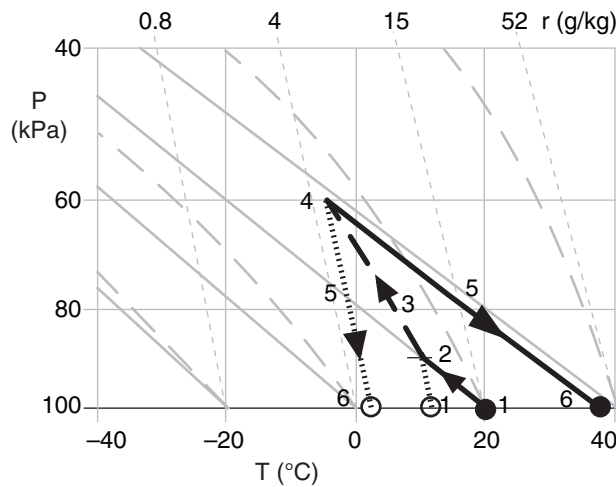

Figure 17.39
 Foehn thermodynamics, plotted on a Stüve thermo diagram. P is pressure, T is temperature, r is water-vapor mixing ratio. Black dots and thick black lines indicate air temperature, while dashed lines and open circles indicate humidity. The numbers 1 - 6 correspond to the numbered locations in the previous figure.

eas of fair weather and light winds. Over mid-latitude land, katabatic winds exist only at night and are usually weak, while on the slopes of Antarctica they can exist for days and can become strong. Boras are driven by the inertia of strong upstream winds that form in regions of low pressure and strong horizontal pressure gradient. They can last for several days. Although both phenomena are cold downslope winds, they are driven by different dynamics.

Foehns and Chinooks

One mechanism for creating Foehn winds does not require clouds and precipitation. If the mountain height H is greater than the thickness z_i of cold air upstream, then the cold air is dammed behind the mountain and does not flow over (Fig. 17.37). The strong warm winds aloft can flow over the ridge top, and can warm further upon descending adiabatically on the lee side. The result is a warm, dry, downslope wind called the **Foehn**.

Foehn winds were originally named for the southerly winds from Italy that blow over the Alps and descend in Austria, Germany, and Switzerland. A similar downslope wind is called the **chinook** just east of the Rocky Mountains in the USA and Canada. Other names in different parts of the world are **zonda** (Argentina), **austru** (Romania), **aspres** (France). The onset of foehn winds in winter can be accompanied with a very rapid temperature increase at the surface. If the warm and very dry air flows over snowy ground, it rapidly melts and sublimates the snow, and is nicknamed “snow eater”.

Another Foehn mechanism is based on net latent heating associated with condensation and precipitation on the upwind side of the mountain range. Consider an air parcel before it flows over a mountain, such as indicated at point (1) in Fig. 17.38. Suppose that the temperature is 20°C and dew point is 10°C initially, as indicated by the filled and open circles at point (1) in Fig. 17.39. This corresponds to about 50% relative humidity.

As the air rises along the windward slopes, it cools dry-adiabatically while conserving mixing ratio until the lifting condensation level (LCL) is reached (2). Further lifting is moist adiabatic (3) within the **orographic cloud** (a cloud caused by the terrain). Suppose that most of the condensed water falls out as precipitation on the windward slopes.

Over the summit (4), suppose that the air has risen to a height where the ambient pressure is 60 kPa. The air parcel now has a temperature of about -8°C. As it begins to descend down the lee side, any residual cloud droplets will quickly evaporate in the adiabatically warming air. The trailing edge of the orographic cloud is called a **Foehn wall**, because

it looks like a wall of clouds when viewed from the lowlands downwind.

Continued descent will be dry adiabatic (5) because there are no liquid water drops to cause evaporative cooling. By the time the air reaches its starting altitude on the lee side (6), its temperature has warmed to about 35°C, with a dew point of about -2°C. This is roughly 10% relative humidity.

The net result of this process is: clouds and precipitation form on the windward slopes of the mountain, a Foehn wall forms just downwind of the mountain crest, and there is warming and drying in the lee lowlands.

CANOPY FLOWS

Forests and Crops

The leaf or needle layer of a crop or forest is called a **canopy**. Individual plants or trees in these crops or forests each cause drag on the wind. The average winds in the air space between these **plant-canopy** or **forest-canopy** obstacles is the canopy flow.

Just above the top of the canopy, the flow is approximately logarithmic with height (Fig. 17.40a), as is described in more detail in the Boundary-Layer chapter for statically neutral conditions in the surface layer:

$$M = \frac{u_*}{k} \ln \left(\frac{z-d}{z_0} \right) \quad \text{for } z \geq h_c \quad (17.53)$$

where M is wind speed, z is height above ground, u_* is the **friction velocity** (a measure of the drag force per unit surface area of the ground), $k \approx 0.4$ is the **von Kármán constant**, d is the **displacement distance** ($0 \leq d \leq h_c$), and z_0 is the **roughness length**, for an average canopy-top height of h_c .

If you can measure the actual wind speed M at 3 or more heights z within 20 m above the top of the canopy, then you can use the following procedure to find d , z_0 , and u_* : (1) use a spreadsheet to plot your M values on a linear horizontal axis vs. their $[z-d]$ values on a logarithmic vertical axis; (2) experiment with different values of d until you find the one that aligns your wind points into a straight line; (3) extrapolate that straight line to $M = 0$, and note the resulting intercept on the vertical axis, which gives the roughness length z_0 . (4) Finally, pick any point exactly on the plotted line, and then plug in its M and z values, along with the d and z_0 values just found, to calculate u_* , using eq. (17.53).

If you do not have measurements of wind speed above the canopy top, you can use the following

Solved Example

Air from the Pacific Ocean ($T = 5^\circ\text{C}$, $T_d = 3^\circ\text{C}$, $z = 0$) flows over the Coast Mountains ($z \approx 3000$ m), and descends toward the interior plateau of British Columbia, Canada ($z \approx 1000$ m). Fig. 17.19 shows the topography of this region. Find the final T and T_d .

Solution

Given: $T = 5^\circ\text{C}$, $T_d = 3^\circ\text{C}$, $z = 0$ m initially.

Find: $T = ?^\circ\text{C}$, $T_d = ?^\circ$ at $z = 1000$ m finally.

Use the thermo diagram from chapter 5:

Use the thermo diagram to find that the initial mixing ratio is $r \approx 5$ g/kg. Clouds form as the air rises over the mountains, with base at $z_{LCL} = (0.125 \text{ km}/^\circ\text{C}) \cdot (5 - 3^\circ\text{C}) = 0.25$ km. From there to $z = 3000$ m, the air follows a moist adiabat, reaching $T = T_d \approx -17^\circ\text{C}$.

Assuming all condensate falls out as precipitation on the windward side, the air then descends dry-adiabatically to the town of Williams Lake. The final state is: $T \approx 4^\circ\text{C}$ at $z = 1000$ m, and $T_d \approx -13^\circ\text{C}$.

Check: Units OK. Physics OK.

Discussion: The air is much drier ($RH \approx 25\%$) on the lee side, but nearly the same temperature as initially. This is typical of a foehn wind.

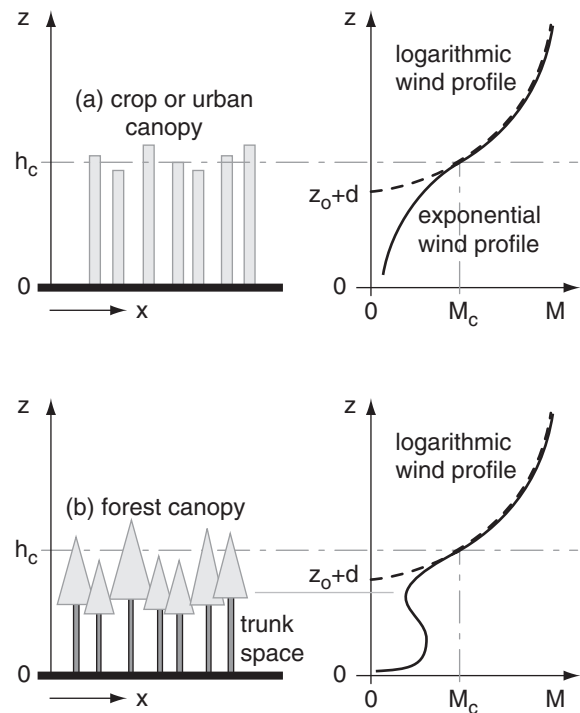

Figure 17.40

Canopy flows for (a) crops or urban canopies, and (b) forest canopies having a relatively open trunk space. Left: sketch of the canopy objects. Right: wind profile (solid line). The dashed black line shows a logarithmic profile extrapolated to zero wind speed M . Average top of the canopy is at height h_c .

Solved Example (§)

Given these wind measurements over a 2 m high corn crop: $[z \text{ (m)}, M \text{ (m/s)}] = [5, 3.87], [10, 5.0], [20, 6.01]$. Find the displacement distance, roughness length, and friction velocity. If the attenuation coefficient is 2.5, plot wind speed M vs. height over $0.5 \text{ m} \leq z \leq 5 \text{ m}$.

Solution

Given: $h_c = 2\text{m}$, $[z \text{ (m)}, M \text{ (m/s)}]$ as listed above, $a = 2.5$. Find: $d = ? \text{ m}$, $z_o = ? \text{ m}$, $u_* = ? \text{ m/s}$, and plot M vs. z .

Guess $d = 0$, and plot M vs. $\log(z-d)$ on a spreadsheet. This d is too small (see graph below), because the curve is concave up. Guess $d = 4$, which is too large, because curve is concave down. After other guesses (some not shown), I find that **$d = 1.3 \text{ m}$** gives the straightest line.

Next, extrapolate on the semi-log graph to $M = 0$, which gives an intercept of **$z_o = 0.2 \text{ m}$** .

Solve eq. (17.53) for $u_* = kM/\ln[(z-d)/z_o]$

$u_* = 0.4(5\text{m/s})/\ln[(10-1.3)/0.2] = 0.53 \text{ m/s}$

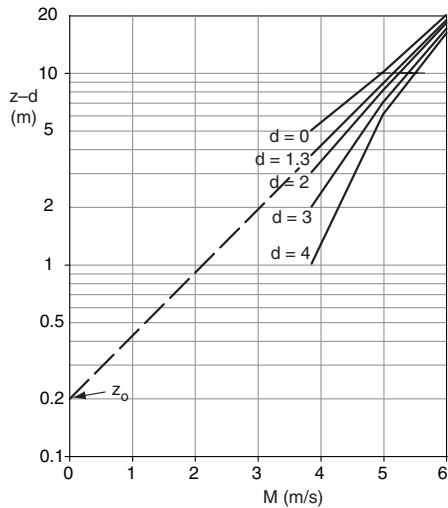

Solve eq. (17.53) for M_c at $z = h_c = 2 \text{ m}$:

$M_c = [(0.53\text{m/s})/0.4] \cdot \ln[(2-1.3)/0.2] = 1.66 \text{ m/s}$

Use eq. (17.54) to find M for a range of heights below h_c , and use eq. (17.53) for heights above h_c :

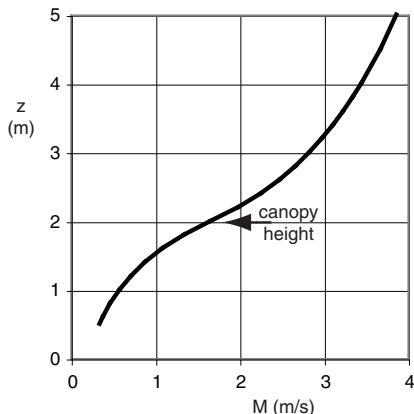

Check: Shape of curve looks reasonable.

Discussion: For this exercise, $z_o = 0.1 h_c$, and $d = 0.65 h_c$. Namely, the crude approximations are OK.

crude approximations to estimate the needed parameters: $d \approx 0.65 \cdot h_c$ and $z_o \approx 0.1 \cdot h_c$. Methods to estimate u_* are given in the Boundary-Layer chapter.

The average wind speed at the average canopy-top height is M_c . For the crude approximations above, we find that $M_c \approx 3.13 u_*$.

Within the top 3/4 of canopy, an exponential formula describes the average wind-speed M profile:

$$M = M_c \cdot \exp \left[a \cdot \left(\frac{z}{h_c} - 1 \right) \right] \quad \text{for } 0.5h_c \leq z \leq h_c \quad (17.54)$$

where a is an **attenuation coefficient** that increases with increasing leaf area and decreases as the mean distance between individual plants increases. Typical values are $a \approx 2.5 - 2.8$ for oats and wheat; $2.0 - 2.7$ for mature corn; 1.3 for sunflowers, $1.0 - 1.1$ for larch and small evergreen trees, and 0.4 for a citrus orchard. The exponential and log-wind speeds match at the average canopy top h_c .

For a forest with relatively open trunk space (i.e., only the tree trunks without many leaves, branches, or smaller underbrush), the previous equation fails. Instead, a weak relative maximum wind speed can occur (Fig. 17.40b). In such forests, if the canopy is very dense, then the sub-canopy (trunk space) flow can be relatively disconnected from the flow above the tree tops. Weak katabatic flows can exist in the trunk space day and night.

Cities

The collection of buildings and trees that make up a city is sometimes called an **urban canopy**. These obstacles cause an average canopy-flow wind similar to that for forests and crops (Fig. 17.40a).

However, winds at any one location in the city can be quite different. For example, the street corridors between tall buildings can channel flow similar to the flow in narrow valleys. Hence these corridors are sometimes called **urban canyons**. Also, taller buildings can deflect down to the surface some of the faster winds aloft. This causes much greater wind speeds and gusts near the base of tall buildings than near the base of shorter buildings.

Cities can be $2 - 12^\circ\text{C}$ degrees warmer than the surrounding rural countryside — an effect called the **urban heat island** (UHI, Fig. 17.41). Reasons include the abundance of concrete, glass and asphalt, which capture and store the solar heat during daytime and reduce the IR cooling at night. Also, vegetated areas are reduced in cities, and rainwater is channeled away through storm drains. Hence, there is less evaporative cooling. Also, fuel and electrical consumption by city residents adds heat via heating, air conditioning, industry, and transportation.

The city–rural temperature difference ΔT_{UHI} is greatest during clear calm nights, because the city stays warm while rural areas cool considerably due to IR radiation to space. Temperature difference is much smaller during daytime. The largest ΔT_{UHI} values occur near the city center, at the greatest density of high buildings and narrow streets. Max ΔT_{UHI} increases with city population N (Fig. 17.42). When averaged over a year (including windy and cloudy periods of minimal UHI), the average ΔT_{UHI} at the city center is only 1 to 2°C.

During periods of fair weather and light synoptic-scale winds, the warm city can generate circulations similar to sea breezes, with inflow of low-altitude rural air toward the city, and rising air over the hottest parts of town. These circulations can enhance clouds, and trigger or strengthen thunderstorms over and downwind of the city. With light to moderate winds, the UHI area is asymmetric, extending much further from the city in the downwind direction (Fig. 17.41), and the effluent (heat, air pollution, odors) from the city can be observed downwind as an **urban plume** (Fig. 17.43).

SUMMARY

The probability of any wind speed can be described by a Weibull distribution, and the distribution of wind directions can be plotted on a wind rose. Regions with greater probability of strong winds are ideal for siting wind turbines to generate electrical power.

During weak synoptic forcing (weak geostrophic winds), local circulations can be driven by thermal forcings. Examples include anabatic (warm upslope) and katabatic (cold downslope) winds, mountain and valley winds, and sea breezes near coastlines.

During strong synoptic forcing, winds can be channeled through gaps, can form downslope windstorms, and can create mountain waves and wave drag. The winds in short gaps can be well described by open-channel hydraulics and Bernoulli’s equation. Winds in longer gaps and fjords are influenced by Coriolis force.

The Bora is a cold downslope wind — driven dynamically by the synoptic scale flow. Foehn winds are also driven dynamically, but are warm, and can be enhanced by orographic precipitation and latent heating. Hydraulic jumps occur downstream of bora winds and in some gap flows as the flow re-adjusts to hydrostatic equilibrium.

Wind and temperature instruments are constructed to minimize dynamic pressure and heating errors. Wind speed is reduced inside plant and ur-

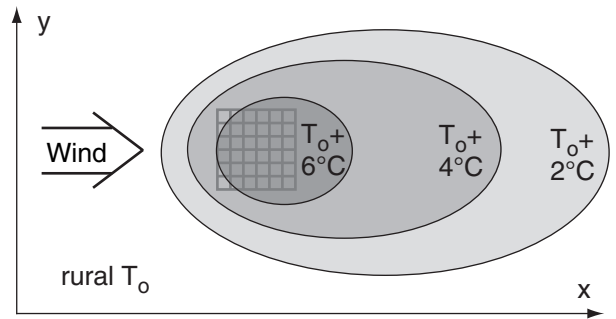

Figure 17.41
An urban heat island at night, where T_o is the rural air temperature. The grid represents city streets.

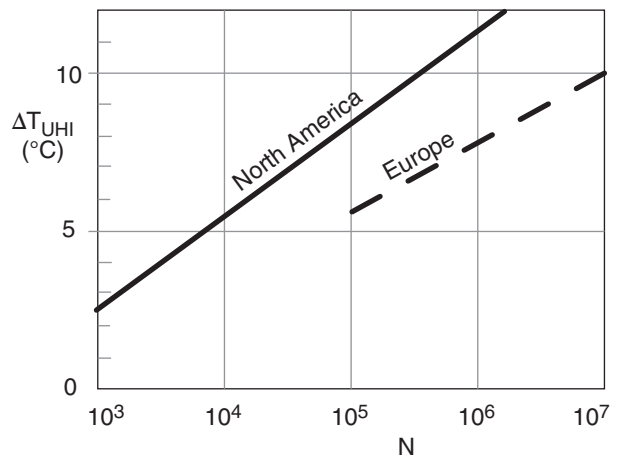

Figure 17.42
Urban-heat-island temperature difference ΔT_{UHI} increases with city population N .

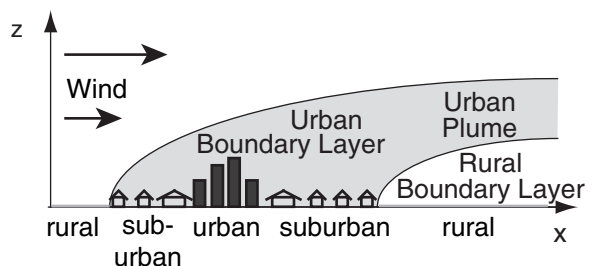

Figure 17.43
Sketch of an urban plume blowing downwind.

ban canopies. The urban-heat-island effect of cities can induce local circulations.

Threads

Winds in this chapter were mostly mesoscale and smaller, as described by Newton's second law of motion (Chapter 10). Positions of synoptic-scale low and high-pressure centers (Chapter 13) and fronts (Chapter 12) drives gap winds, coastal jets, and mountain waves.

Mountain waves, Boras, and Foehns require a statically stable environment (Chapter 5) such as is in the standard atmosphere (Chapter 1). Warm foehn winds can occur by latent heating (Chapters 4 and 5), or by adiabatic warming (Chapter 3) of downslope air. Clouds (Chapter 6) can be created in the updrafts near mountains.

Wind turbines are often sited near hilly regions where wind speed increases. Turbines are designed to withstand the wind shear and gusts typical of the atmospheric boundary layer (Chapter 18).

ON DOING SCIENCE • Simple is Best

Fourteenth century philosopher William of Occam suggested that "the simplest scientific explanation is the best". This tenant is known as **Occam's Razor**, because with it you can cut away the bad theories and complex equations from the good.

But why should the simplest or most elegant be the best? There is no law of nature that says it must be so. It is just one of the philosophies of science, as is the scientific method of Descartes. Ultimately, like any philosophy or religion, it is a matter of faith.

I suggest an alternative tenant: "**a scientific relationship should not be more complex than needed.**" This is motivated by the human body — an amazingly complex system of hydraulic, pneumatic, electrical, mechanical, chemical, and other physical processes that works exceptionally well. In spite of its complexity, the human body is not more complex than needed (as determined by evolution).

Although this alternative tenant is only subtly different from Occam's Razor, it admits that sometimes complex mathematical solutions to physical problems are valid. This tenant is used by a data-analysis method called **computational evolution** (or **gene-expression programming**). This approach creates a population of different algorithms that compete to best fit the data, where the best algorithms are allowed to persist with mutation into the next generation while the less-fit algorithms are culled via computational natural selection.

EXERCISES

Numerical Problems

N1.(§) Plot the probability of wind speeds using a Weibull distribution with a resolution of 0.5 m/s, and $M_o = 8$ m/s, for $\alpha =$

- a. 1.0 b. 1.5 c. 2.0 d. 2.5 e. 3.0 f. 3.5 g. 4.0
h. 4.5 i. 5.0 j. 5.5 k. 6.0 m. 7 n. 8 o. 9

N2. A wind turbine of blade radius 25 m runs at 35% efficiency. At sea level, find the theoretical power (kW) for winds (m/s) of:

- a. 1 b. 2 c. 3 d. 4 e. 5 f. 6 g. 7 h. 8
i. 9 j. 10 k. 11 m. 12 n. 13 o. 14 p. 15

N3. Find the equilibrium updraft speed (m/s) of a thermal in a 2 km boundary layer with environmental temperature 15°C. The thermal temperature (°C) is: a. 16 b. 16.5 c. 17 d. 17.5 e. 18 f. 18.5

- g. 19 h. 19.5 i. 20 j. 20.5 k. 21 m. 21.5

N4. Anabatic flow has a temperature excess of 4°C. Find the buoyant along-slope pressure gradient force per unit mass for a slope of angle (°):

- a. 10 b. 15 c. 20 d. 25 e. 30 f. 35 g. 40
h. 45 i. 50 j. 55 k. 60 m. 65 n. 70 o. 75

N5.(§) Plot katabatic wind speed (m/s) vs. downslope distance (m) if the environment is 20°C and the cold katabatic air is 15°C. The slope angle (°) is:

- a. 10 b. 15 c. 20 d. 25 e. 30 f. 35 g. 40
h. 45 i. 50 j. 55 k. 60 m. 65 n. 70 o. 75

N6. Find the equilibrium downslope speed (m/s) for the previous problem, if the katabatic air is 5 m thick and the drag coefficient is 0.002.

N7. Find the depth (m) of the thermal internal boundary layer 2 km downwind of the coastline, for an environment with wind speed 8 m/s and $\gamma = 4$ K/km. The surface kinematic heat flux (K·m/s) is

- a. 0.04 b. 0.06 c. 0.08 d. 0.1 e. 0.12
f. 0.14 g. 0.16 h. 0.18 i. 0.2 j. 0.22

N8. Assume $T_v = 20^\circ\text{C}$. Find the speed (m/s) of advance of the sea-breeze front, for a flow depth of 700 m and a temperature excess $\Delta\theta$ (K) of:

- a. 1.0 b. 1.5 c. 2.0 d. 2.5 e. 3.0 f. 3.5 g. 4.0
h. 4.5 i. 5.0 j. 5.5 k. 6.0 m. 7 n. 8 o. 9

N9. For the previous problem, find the sea-breeze wind speed (m/s) at the coast.

N10. For a sea-breeze frontal speed of 5 m/s, find the expected maximum distance (km) of advance of the sea-breeze front for a latitude ($^{\circ}$) of

- a. 10 b. 15 c. 20 d. 25 e. 80 f. 35 g. 40
h. 45 i. 50 j. 55 k. 60 m. 65 n. 70 o. 75

N11. What is the shallow-water wave phase speed (m/s) for a water depth (m) of:

- a. 2 b. 4 c. 6 d. 8 e. 10 f. 15 g. 20
h. 25 i. 30 j. 40 k. 50 m. 75 n. 100 o. 200

N12. Assume $|g|/T_v = 0.0333 \text{ m}\cdot\text{s}^{-2}\cdot\text{K}^{-1}$. For a cold layer of air of depth 50 m under warmer air, find the surface (interfacial) wave phase speed (m/s) for a virtual potential temperature difference (K) of:

- a. 1.0 b. 1.5 c. 2.0 d. 2.5 e. 3.0 f. 3.5 g. 4.0
h. 4.5 i. 5.0 j. 5.5 k. 6.0 m. 7 n. 8 o. 9

N13. For the previous problem, find the value of the Froude number Fr_1 . Also, classify this flow as subcritical, critical, or supercritical. Given $M = 15 \text{ m/s}$.

N14. Assume $|g|/T_v = 0.0333 \text{ m}\cdot\text{s}^{-2}\cdot\text{K}^{-1}$. Find the internal wave horizontal group speed (m/s) for a stably stratified air layer of depth 400 m, given $\Delta\theta_v/\Delta z$ (K/km) of:

- a. 1.0 b. 1.5 c. 2.0 d. 2.5 e. 3.0 f. 3.5 g. 4.0
h. 4.5 i. 5.0 j. 5.5 k. 6.0 m. 7 n. 8 o. 9

N15. For the previous problem, find the value of the Froude number Fr_2 . Also, classify this flow as subcritical, critical, or supercritical.

N16. Winds of 10 m/s are flowing in a valley of 10 km width. Further downstream, the valley narrows to the width (km) given below. Find the wind speed (m/s) in the constriction, assuming constant depth flow.

- a. 1.0 b. 1.5 c. 2.0 d. 2.5 e. 3.0 f. 3.5 g. 4.0
h. 4.5 i. 5.0 j. 5.5 k. 6.0 m. 7 n. 8 o. 9

N17. Assume $|g|/T_v = 0.0333 \text{ m}\cdot\text{s}^{-2}\cdot\text{K}^{-1}$. For a two-layer atmospheric system flowing through a short gap, find the maximum expected gap wind speed (m/s). Flow depth is 300 m, and the virtual potential temperature difference (K) is:

- a. 1.0 b. 1.5 c. 2.0 d. 2.5 e. 3.0 f. 3.5 g. 4.0
h. 4.5 i. 5.0 j. 5.5 k. 6.0 m. 7 n. 8 o. 9

N18. Find the long-gap geostrophic wind (m/s) at latitude 50° , given $|g|/T_v = 0.0333 \text{ m}\cdot\text{s}^{-2}\cdot\text{K}^{-1}$ and $\Delta\theta_v = 3^{\circ}\text{C}$, and assuming that the slope of the top cold-air surface is given by the height change (km) below across a valley 10 km wide.

- a. 0.3 b. 0.4 c. 0.5 d. 0.6 e. 0.7
f. 0.8 g. 0.9 h. 1.0 i. 1.1 j. 1.2

- k. 2.4 m. 2.6 n. 2.8 o. 3

N19. Find the external Rossby radius of deformation (km) for a coastally trapped jet that rides against a mountain range of 2500 m altitude at latitude ($^{\circ}$) given below, for air that is colder than its surroundings by 10°C . Assume $|g|/T_v = 0.0333 \text{ m}\cdot\text{s}^{-2}\cdot\text{K}^{-1}$.

- a. 80 b. 85 c. 20 d. 25 e. 30 f. 35 g. 40
h. 45 i. 50 j. 55 k. 60 m. 65 n. 70 o. 75

N20. Assume $|g|/T_v = 0.0333 \text{ m}\cdot\text{s}^{-2}\cdot\text{K}^{-1}$. Find the natural wavelength of air, given

- a. $M = 2 \text{ m/s}$, $\Delta T/\Delta z = 5^{\circ}\text{C}/\text{km}$
b. $M = 20 \text{ m/s}$, $\Delta T/\Delta z = -8^{\circ}\text{C}/\text{km}$
c. $M = 5 \text{ m/s}$, $\Delta T/\Delta z = -2^{\circ}\text{C}/\text{km}$
d. $M = 20 \text{ m/s}$, $\Delta T/\Delta z = 5^{\circ}\text{C}/\text{km}$
e. $M = 5 \text{ m/s}$, $\Delta T/\Delta z = -8^{\circ}\text{C}/\text{km}$
f. $M = 2 \text{ m/s}$, $\Delta T/\Delta z = -2^{\circ}\text{C}/\text{km}$
g. $M = 5 \text{ m/s}$, $\Delta T/\Delta z = 5^{\circ}\text{C}/\text{km}$
h. $M = 2 \text{ m/s}$, $\Delta T/\Delta z = -8^{\circ}\text{C}/\text{km}$

N21. For a mountain of width 25 km, find the Froude number Fr_3 for the previous problem. Draw a sketch of the type of mountain waves that are likely for this Froude number.

N22. For the previous problem, find the angle of the wave crests, and the wave-drag force per unit mass. Assume $H = 1000 \text{ m}$ and $h_w = 11 \text{ km}$.

N23(S). Plot the wavy path of air as it flows past a mountain, given an initial vertical displacement of 300 m, a wavelength of 12.5 km, and a damping factor of

- a. 1.0 b. 1.5 c. 2.0 d. 2.5 e. 3.0 f. 3.5 g. 4.0
h. 4.5 i. 5.0 j. 5.5 k. 6.0 m. 7 n. 8 o. 9

N24(S) Given a temperature dew-point spread of 1.5°C at the initial (before-lifting) height of air in the previous problem, identify which wave crests contain lenticular clouds.

N25. Cold air flow speed 12 m/s changes to 3 m/s after a hydraulic jump. Assume $|g|/T_v = 0.0333 \text{ m}\cdot\text{s}^{-2}\cdot\text{K}^{-1}$. How high can the hydraulic jump rise if the exit velocity (m/s) is

- a. 1.0 b. 1.5 c. 2.0 d. 2.5 e. 3.0 f. 3.5 g. 4.0
h. 4.5 i. 5.0 j. 5.5 k. 6.0 m. 7 n. 8 o. 9

N26. Assuming standard sea-level density and streamlines that are horizontal, find the pressure change given the following velocity (m/s) change:

- a. 1.0 b. 1.5 c. 2.0 d. 2.5 e. 3.0 f. 3.5 g. 4.0
h. 4.5 i. 5.0 j. 5.5 k. 6.0 m. 7 n. 8 o. 9

N27. Wind at constant altitude decelerates from 12 m/s to the speed (m/s) given below, while passing through a wind turbine. What opposing net pressure difference (Pa) would have caused the same deceleration in laminar flow?

- a. 1.0 b. 1.5 c. 2.0 d. 2.5 e. 3.0 f. 3.5 g. 4.0
h. 4.5 i. 5.0 j. 5.5 k. 6.0 m. 7 n. 8 o. 9

N28. Air with pressure 100 kPa is initially at rest. It is accelerated isothermally over a flat 0°C snow surface as it is sucked toward a household ventilation system. What is the final air pressure (kPa) just before entering the fan if the final speed (m/s) through the fan is:

- a. 1 b. 2 c. 3 d. 4 e. 5 f. 6 g. 7 h. 8
i. 9 j. 10 k. 11 m. 12 n. 13 o. 14 p. 15

N29. A short distance behind the jet engine of an aircraft flying in level flight, the exhaust temperature is 500°C. After the jet exhaust decelerates to zero, what is the final exhaust air temperature (°C), neglecting conduction and mixing, assuming the initial jet-blast speed (m/s) is:

- a. 100 b. 125 c. 150 d. 175 e. 200 f. 210 g. 220
h. 230 i. 240 j. 250 k. 260 m. 270 n. 280 o. 290

N30. An 85 kW electric wind machine with a 3 m radius fan blade is used in an orchard to mix air so as to reduce frost damage on fruit. The fan horizontally accelerates the air from calm to the speed (m/s) given below. Find the temperature change (°C) across the fan, neglecting mixing with the environmental air.

- a. 6 b. 6.5 c. 7 d. 7.5 e. 8 f. 8.5 g. 9
h. 9.5 i. 10 j. 10.5 k. 11 m. 12 n. 13 o. 14

N31. Tornadoic air of temperature 25°C blows with speed (m/s) given below, except that it stagnates upon hitting a barn. Find the final stagnation temperature (°C) and pressure change (kPa).

- a. 100 b. 125 c. 150 d. 175 e. 200 f. 210 g. 220
h. 230 i. 240 j. 250 k. 260 m. 270 n. 280 o. 290

N32. Find the speed of sound (m/s) and Mach number for $M_{air} = 100$ m/s, given air of temperature (°C):

- a. -50 b. -45 c. -40 d. -35 e. -30
f. -25 g. -20 h. -15 i. -10 j. -5
k. 0 m. 5 n. 10 o. 15 p. 20

N33. Water flowing through a pipe with speed 2 m/s and pressure 100kPa accelerates to the speed (m/s) given below when it flows through a constriction. What is the fluid pressure (kPa) in the constriction? Neglect drag against the pipe walls.

- a. 6 b. 6.5 c. 7 d. 7.5 e. 8 f. 8.5 g. 9

- h. 9.5 i. 10 j. 10.5 k. 11 m. 12 n. 13 o. 14

N34. For the bora solved example, redo the calculation assuming that the initial inversion height (km) is:

- a. 1.1 b. 1.15 c. 1.25 d. 1.3 e. 1.35
f. 1.4 g. 1.45 h. 1.5 i. 1.55 j. 1.6
k. 1.65 m. 1.7 n. 1.75 o. 1.8 p. 1.85

N35. Use a thermodynamic diagram. Air of initial temperature 10°C and dew point 0°C starts at a height where the pressure (kPa) is given below. This air rises to height 70 kPa as it flows over a mountain, during which all liquid and solid water precipitate out. Air descends on the lee side of the mountain to an altitude of 95 kPa. What is the temperature, dew point, and relative humidity of the air at its final altitude? How much precipitation occurred on the mountain? [Hint: use a thermo diagram.]

- a. 104 b. 102 c. 100 d. 98 e. 96 f. 94 g. 92
h. 90 i. 88 j. 86 k. 84 m. 82 n. 80

N36. Plot wind speed vs. height, for heights between $0.25 h_c$ and $5 h_c$, where h_c is average plant canopy height. Given:

Plant	h_c (m)	$u_*(\text{m/s})$	attenuation coef.
a. Wheat	1.0	0.5	2.6
b. Wheat	1.0	0.75	2.6
c. Soybean	1.0	0.5	3.5
d. Soybean	1.0	0.75	3.5
e. Oats	1.5	0.5	2.8
f. Oats	1.5	0.75	2.8
g. Corn	2.0	0.5	2.7
h. Corn	2.0	0.75	2.7
i. Corn	2.5	0.5	2.2
j. Corn	2.5	0.75	2.2
k. Sunflower	2.75	0.5	1.3
m. Sunflower	2.75	0.75	1.3
n. Pine	3.0	0.5	1.1
o. Pine	3.0	0.25	1.1
p. Orchard	4.0	0.5	0.4
q. Orchard	4.0	0.25	0.4
r. Forest	20.	0.5	1.7
s. Forest	20.	0.25	1.7

N37. Estimate the urban heat island temperature excess compared to the surrounding rural countryside, for a N. American city of population

- a. 2000 b. 5000 c. 7000 d. 10,000 e. 20,000
f. 50k g. 70k h. 100k i. 200k j. 500k k. 700k
m. 1M n. 2M

Understanding & Critical Evaluation

U1. For a Weibull distribution, what is the value of the probability in any one bin as the bin size becomes infinitesimally small? Why?

- U2(S). Create a computer spreadsheet with location and spread parameters in separate cells. Create and plot a Weibull frequency distribution for winds by referencing those parameters. Then try changing the parameters to see if you can get the Weibull distribution to look like other well-known distributions, such as Gaussian (symmetric, bell shaped), exponential, or others.
- U3. Why was an asymmetric distribution such as the Weibull distribution chosen to represent winds?
- U4. What assumptions were used in the derivation of Betz' Law, and which of those assumptions could be improved?
- U5. To double the amount of electrical power produced by a wind turbine, wind speed must increase by what percentage, or turbine radius increase by what percentage?
- U6. For the Weibull distribution as plotted in Fig. 17.1, find the total wind power associated with it.
- U7. In Fig. 17.5, what determines the shape of the wind-power output curve between the cut-in and rated points?
- U8. List and explain commonalities among the equations that describe the various thermally-driven local flows.
- U9. If thermals with average updraft velocity of $W = 5$ m/s occupy 40% of the horizontal area in the boundary layer, find the average downdraft velocity.
- U10. What factors might affect rise rate of the thermal, in addition to the ones already given in this chapter?
- U11. Anabatic and lenticular clouds were described in this chapter. Compare these clouds and their formation mechanisms. Is it possible for both clouds to occur simultaneously over the same mountain?
- U12. Is the equation describing the anabatic pressure gradient force valid or reasonable in the limits of 0° slope, or 90° slope. Explain.
- U13. Explain in terms of Bernoulli's equation the horizontal pressure gradient force acting on anabatic winds.
- U14. What factors control the shape of the katabatic wind profile, as plotted in Fig. 17.9?
- U15. The solved example for katabatic wind shows the curves from eqs. (17.8) and (17.9) as crossing. Given the factors that appear in those equations, is a situation possible where the curves never cross? Describe.
- U16. Suppose a mountain valley exits right at a coastline. For synoptically weak conditions (near zero geostrophic wind), describe how would the mountain/valley circulation and sea-breeze circulation interact. Illustrate with drawings.
- U17. The thermal internal boundary layer can form both during weak- and strong-wind synoptic conditions. Why?
- U18. For stronger land-sea temperature contrasts, which aspects of the sea-breeze would change, and which would be relatively unchanged? Why?
- U19. At 30° latitude, can the sea-breeze front advance an infinite distance from the shore? Why?
- U20. In the Southern Hemisphere, draw a sketch of the sea-breeze-vs.-time hodograph, and explain it.
- U21. For what situations would open-channel hydraulics NOT be a good approximation to atmospheric local flows? Explain.
- U22. Interfacial (surface) wave speed was shown to depend on average depth of the cold layer of air. Is this equation valid for any depth? Why?
- U23. In deriving eq. (17.17) for internal waves, we focused on only the fastest wavelengths. Justify.
- U24. In what ways is the Froude number for incompressible flows similar to the Mach number for compressible flows?
- U25. If supercritical flows tend to "break down" toward subcritical, then why do supercritical flows exist at all in the atmosphere?
- U26. Is it possible to have supercritical flow in the atmosphere that does NOT create a hydraulic jump when it changes to subcritical? Explain?
- U27. Contrast the nature of gap winds through short and long gaps. Also, what would you do if the gap length were in between short and long?
- U28. For gap winds through a long gap, why are they less likely to form in summer than winter?

U29. Can coastally trapped jets form on the east coast of continents in the N. Hemisphere? If so, explain how the process would work.

U30. It is known from measurements of the ionosphere that the vertical amplitude of mountain waves increases with altitude. Explain this using Bernoulli's equation.

U31. What happens to the natural wavelength of air for statically unstable conditions?

U32. Why are lenticular clouds called **standing lenticular**?

U33. Compare and contrast the 3 versions of the Froude number. Do they actually describe the same physical processes? Why?

U34. Is there any max limit to the angle of mountain wave crests (see Fig. 17.31)? Comment.

U35. If during the course of a day, the wind speed is constant but the wind direction gradually changes direction by a full 360° , draw a graph of the resulting streamline, streakline, and path line at the end of the period. Assume continuous emissions from a point source during the whole period.

U36. Identify the terms of Bernoulli's equation that form the hydrostatic approximation. According to Bernoulli's equation, what must happen or not happen in order for hydrostatic balance to be valid?

U37. Describe how the terms in Bernoulli's equation vary along a mountain-wave streamline as sketched in Fig. 17.29.

U38. If a cold air parcel is given an upward push in a warmer environment of uniform potential temperature, describe how the terms in Bernoulli's equation vary with parcel height.

U39. For compressible flow, show if (and how) the Bernoulli equations for isothermal and adiabatic processes reduce to the basic incompressible Bernoulli equation under conditions of constant density.

U40. In the solved example for the pressure variation across a wind turbine, hypothesize why the actual pressure change has the variation that was plotted.

U41. In Fig. 17.34, would it be reasonable to move the static pressure port to the top center of the darkly shaded block, given no change to the streamlines drawn? Comment on potential problems with a static port at that location.

U42. Design a thermometer mount on a fast aircraft that would not be susceptible to dynamic warming. Explain why your design would work.

U43. In Fig. 17.34, speculate on how the streamlines would look if the approaching flow was supersonic. Draw your streamlines, and justify them.

U44. Comment on the differences and similarities of the two mechanisms shown in this Chapter for creating Foehn winds.

U45. For Bora winds, if the upwind cold air was over an elevated plateau, and the downwind lowland was significantly lower than the plateau, how would Bora winds be different, if at all? Why?

U46. If the air in Fig. 17.38 went over a mountain but there was no precipitation, would there be a Foehn wind?

U47. Relate the amount of warming of a Foehn wind to the average upstream wind speed and the precipitation rate in mm/h.

U48. How sensitive is the solution for wind speed above a plant canopy? [Hint: see the solved example in the canopy flow section.] Namely, if you have a small error in estimating displacement distance d , are the resulting errors in friction velocity u_* and roughness length z_o relatively small or large?

Web-Enhanced Questions

W1. Search the web for wind-rose graphs for a location (weather station or airport) near you, or other location specified by your instructor.

W2. Search the web for wind-speed distributions for a weather station near you. Relate this distribution to extreme or record-breaking winds.

W3. Find on the web climatological maps giving locations of persistent, moderate winds. These are favored locations for wind turbine farms. Also search the web for locations of existing turbine farms.

W4. Search the web for a weather map showing vertical velocities over your country or region. Sometimes, these vertical velocities are given as omega (ω) rather than w , where ω is the change of pressure

with time experienced by a vertically moving parcel, and is defined in the Extratropical Cyclone chapter. What is the range of vertical velocities on this particular day, in m/s?

W5. Search the web for the highest resolution (hopefully 0.5 km or better resolution) visible satellite imagery for your area. Which parts of the country have rising thermals, based on the presence of cumulus clouds at the top of the thermals?

W6. Search the web for lidar (laser radar) images of thermals in the boundary layer.

W7. Search the web for the highest resolution (hopefully 0.5 km or better resolution) visible satellite imagery for your area. Also search for an upper-air sounding (i.e., thermo diagram) for your area. Does the depth of the mixed layer from the thermo diagram agree with the diameter of thermals (clouds) visible in the satellite image? Comment.

W8. Access IR high resolution satellite images over cloud-free regions of the Rocky Mountains (or Cascades, Sierra-Nevada, Appalachians, or other significant mountains) for late night or early morning during synoptic conditions of high pressure and light winds. Identify those regions of cold air in valleys, as might have resulted from katabatic winds. Sometimes such regions can be identified by the fog that forms in them.

W9. Search the web for weather station observations at the mouth of a valley. Plotted meteograms of wind speed and direction are best to find. See if you can find evidence of mountain/valley circulations in these station observations, under weak synoptic forcing.

W10. Same as the previous problem, but to detect a sea breeze for a coastal weather station.

W11. Search the web for satellite observations of the sea breeze, evident as changes in cloudiness parallel to the coastline.

W12. Search the web for information on how tsunami on the ocean surface travel at the shallow-water wave speed as defined in this chapter, even when the waves are over the deepest parts of the ocean. Explain.

W13. Search the web for images of hydraulic jump in the atmosphere. If you can't find any, then find images of hydraulic jump in water instead.

W14. Access images from digital elevation data, and find examples of short and long gaps through mountain ranges for locations other than Western Canada.

W15. Search the web for news stories about dangerous winds along the coast, but limit this search to only coastally-trapped jets. If sufficient information is given in the news story, relate the coastal jet to the synoptic weather conditions.

W16. Access visible high-resolution satellite photos of mountain wave clouds downwind of a major mountain range. Measure the wavelength from these images, and compare with the wind speed accessed from upper air soundings in the wave region. Use those data to estimate the Brunt-Väisälä frequency.

W17. Access from the web photographs taken from ground level of lenticular clouds. Also, search for **iridescent** clouds on the web, to find if any of these are lenticular clouds.

W18. Access from the web pilot reports of turbulence, chop, or mountain waves in regions downwind of mountains. Do this over several days, and show how these reports vary with wind speed and static stability.

W19. Access high-resolution visible satellite images from the web during clear skies, that show the smoke plume from a major source (such as Gary, Indiana, or Sudbury, Ontario, or a volcano, or a forest fire). Assume that this image shows a streakline. Also access the current winds from a weather map corresponding roughly to the altitude of the smoke plume, from which you can infer the streamlines. Compare the streamlines and streaklines, and speculate on how the flow has changed over time, if at all. Also, draw on your printed satellite photo the path lines for various air parcels within the smoke plume.

W20. From the web, access weather maps that show streamlines. These are frequently given for weather maps of the jet stream near the tropopause (at 20 to 30 kPa). Also access from the web weather maps that plot the actual upper air winds from rawinsonde observations, valid at the same time and altitude as the streamline map. Compare the instantaneous winds with the streamlines.

W21. From the web, access a sequence of weather maps of streamlines for the same area. Locate a point on the map where the streamline direction has

changed significantly during the sequence of maps. Assume that smoke is emitted continuously from that point. On the last map of the sequence, plot the streakline that you would expect to see. (Hint, from the first streamline map, draw a path line for an air parcel that travels until the time of the next streamline map. Then, using the new map, continue finding the path of that first parcel, as well as emit a new second parcel that you track. Continue the process until the tracks of all the parcels end at the time of the last streamline map. The locus of those parcels is a rough indication of the streakline.)

W22. Access from the web information for aircraft pilots on how the pitot tube works, and/or its calibration characteristics for a particular model of aircraft.

W23. Access from the web figures that show the amount of destruction for different intensities of tornado winds. Prepare a table giving the dynamic pressures and forces on the side of a typical house for each of those different wind categories.

W24. Access from the web news stories of damage to buildings or other structures caused by Boras, mountain waves, or downslope windstorms.

W25. Access from the web data or images that indicate typical height of various mature crops (other than the ones already given at the end of the Numerical exercises).

W26. Access from the web the near-surface air temperature at sunrise in or just downwind of a large city, and compare with the rural temperature.

Synthesis Questions

S1. Suppose that in year 2100 everyone is required by law to have their own wind turbine. Since wind turbines take power from the wind, the wind becomes slower. What effect would this have on the weather and climate, if any?

S2. If fair-weather thermals routinely rose as high as the tropopause without forming clouds, comment on changes to the weather and climate, if any.

S3. Suppose that katabatic winds were frictionless. Namely, no turbulence, no friction against the ground, and no friction against other layers of air. Speculate on the shape of the vertical wind profile of the katabatic winds, and justify your arguments.

S4. If a valley has two exists, how would the mountain and valley winds behave?

S5. Suppose that katabatic winds flow into a bowl-shaped depression instead of a valley. Describe how the airflow would evolve during the night.

S6. If warm air was not less dense than cold, could sea breezes form? Explain.

S7. Why does the cycling in a sea-breeze hodograph not necessarily agree with the timing of the pendulum day?

S8. What local circulations would disappear if air density did not vary with temperature? Justify.

S9. Can a Froude number be defined based on deep-water waves rather than shallow-water waves? If so, write an equation for the resulting Froude number, and suggest applications for it in the atmosphere.

S10. What if waves could carry no information and no energy. How would the critical nature of the flow change, if at all?

S11. If the Earth did not rotate, compare the flow through short and long gaps through mountains.

S12. If no mountains existing along coasts, could there ever be strong winds parallel to the coast?

S13. If mountain-wave drag causes the winds to be slower, does that same drag force cause the Earth to spin faster? Comment.

S14. Suppose that mountain-wave drag worked oppositely, and caused winds to accelerate aloft. How would the weather & climate be different, if at all?

S15. Is it possible for a moving air parcel to not be traveling along a streamline? Comment.

S16. Suppose that Bernoulli's equation says that pressure decreases as velocity decreases along a streamline of constant height. How would the weather and climate be different, if at all? Start by commenting how Boras would be different, if at all.

S17. Suppose you are a 2 m tall person in a town with average building height of 8 m. How would the winds that you feel be different (if at all) than the winds felt by a 0.2 m tall cat in a young corn field of average height 0.8 m?

S18. If human population continued to grow until all land areas were urban, would there be an urban heat island? Justify, and relate to weather changes.