

AIR POLLUTION DISPERSION

CONTENTS

Dispersion Factors	724
Air Quality Standards	725
Turbulence Statistics	726
Review of Basic Definitions	726
Isotropy (again)	727
Pasquill-Gifford (PG) Turbulence Types	728
Dispersion Statistics	728
Snapshot vs. Average	728
Center of Mass	729
Standard Deviation – Sigma	729
Gaussian Curve	730
Nominal Plume Edge	730
Taylor's Statistical Theory	731
Passive Conservative Tracers	731
Dispersion Equation	731
Dispersion Near & Far from the Source	732
Dispersion In Neutral & Stable Boundary Layers	732
Plume Rise	732
Neutral Boundary Layers	733
Stable Boundary Layers	733
Gaussian Concentration Distribution	734
Dispersion In Unstable Boundary Layers (Convective Mixed Layers)	735
Relevant Variables	735
Physical Variables:	735
Mixed-Layer Scaling Variables:	735
Dimensionless Scales:	736
Plume Centerline	736
Crosswind Integrated Concentration	736
Concentration	737
Summary	737
Threads	738
Exercises	739
Numerical Problems	739
Understanding & Critical Evaluation	741
Web-Enhanced Questions	742
Synthesis Questions	743

19 Every living thing pollutes. Life is a chemical reaction, where input chemicals such as food and oxygen are converted into growth or motion. The reaction products are waste or pollution.

The only way to totally eliminate pollution is to eliminate life — not a particularly appealing option. However, a system of world-wide population control could stem the increase of pollution, allowing residents of our planet to enjoy a high quality of life.

Is pollution bad? From an anthropocentric point of view, we might say “yes”. To do so, however, would deny our dependence on pollution. In the Earth’s original atmosphere, there was very little oxygen. Oxygen is believed to have formed as pollution from plant life. Without this pollutant, animals such as humans would likely not exist now.

However, it is reasonable to worry about other **chemicals that threaten our quality of life**. We call such chemicals **pollutants**, regardless of whether they form naturally or **anthropogenically** (man-made). Many of the natural sources are weak emissions from large area sources, such as forests or swamps. Anthropogenic sources are often concentrated at points, such as at the top of smoke stacks (Fig. 19.1). Such high concentrations are particularly hazardous, and been heavily studied.

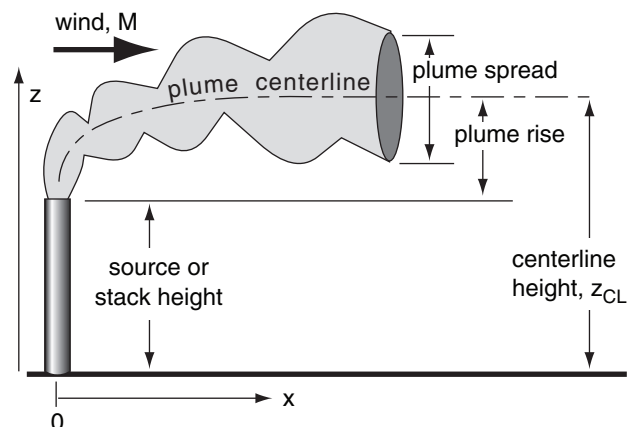

Figure 19.1
Pollutant plume characteristics.

FOCUS • Pollutant Concentration Units

The amount of a pollutant in the air can be given as a **fraction** or **ratio**, q . This is the amount (moles) of pollution divided by the total amount (moles) of all constituents in the air. For air quality, the ratios are typically reported in **parts per million (ppm)**. For example, 10 ppm means 10 parts of pollutant are contained within 10^6 parts of air. For smaller amounts, **parts per billion (ppb)** are used.

Although sometimes the ratio of masses is used (e.g., **ppmm** = parts per million by mass), usually the ratio of volumes is used instead (**ppmv** = parts per million by volume).

Alternately, the amount can be given as a **concentration**, c , which is the mass of pollutant in a cubic meter of air. For air pollution, units are often micrograms per cubic meter ($\mu\text{g}/\text{m}^3$). Higher concentrations are reported in milligrams per cubic meter, (mg/m^3), while lower concentrations can be in nanograms per cubic meter (ng/m^3).

The conversion between fractions and concentrations is

$$q(\text{ppmv}) = \frac{a \cdot T}{P \cdot M_s} \cdot c(\mu\text{g}/\text{m}^3)$$

where T is absolute temperature (Kelvin), P is total atmospheric pressure (kPa), M_s is the molecular weight of the pollutant, and $a = 0.008314 \text{ kPa} \cdot \text{K}^{-1} \cdot (\text{ppmv}) \cdot (\mu\text{g}/\text{m}^3)^{-1}$.

For a standard atmosphere at sea level, where temperature is 15°C and pressure is 101.325 kPa, the equation above reduces to

$$q(\text{ppmv}) = \frac{b}{M_s} \cdot c(\mu\text{g}/\text{m}^3)$$

where $b = 0.02363 (\text{ppmv}) / (\mu\text{g}/\text{m}^3)$.

For example, nitrogen dioxide (NO_2) has a molecular weight of $M_s = 46.01$ (see Table 1-2 in Chapter 1). If concentration $c = 100 \mu\text{g}/\text{m}^3$ for this pollutant, then the equation above gives a volume fraction of $q = (0.02363/46.01) \cdot (100) = 0.051 \text{ ppmv}$.

Science Graffiti

“The solution to pollution is dilution.”

– Anonymous.

This aphorism was accepted as common sense during the 1800s and 1900s. By building taller smoke stacks, more pollutants could be emitted, because the pollutants would mix with the surrounding clean air and become dilute before reaching the surface.

However, by 2000, society started recognizing the global implications of emitting more pollutants. Issues included greenhouse gases, climate change, and stratospheric ozone destruction. Thus, government regulations changed to include total emission limits.

DISPERSION FACTORS

The stream of polluted air downwind of a smoke stack is called a **smoke plume**. If the plume is buoyant, or if there is a large effluent velocity out of the top of the smoke stack, the center of the plume can rise above the initial emission height. This is called **plume rise**.

The word “plume” in air pollution work means a long, slender, nearly-horizontal region of polluted air. However, the word “plume” in atmospheric boundary-layer (ABL) studies refers to the relatively wide, nearly vertical updraft portion of buoyant air that is convectively overturning. Because smoke plumes emitted into the boundary layer can be dispersed by convective plumes, one must take great care to not confuse the two usages of the word “plume”.

Dispersion is the name given to the spread and movement of pollutants. Pollution dispersion depends on

- wind speed and direction
- plume rise, and
- atmospheric turbulence.

Pollutants disperse with time by mixing with the surrounding cleaner air, resulting in an increasingly dilute mixture within a spreading smoke plume.

Wind and **turbulence** are characteristics of the ambient atmosphere, as were described in earlier chapters. While emissions out of the top of the stack often have strong internal turbulence, this quickly decays, leaving the ambient atmosphere to do the majority of the dispersing.

The direction that the effluent travels is controlled by the local, synoptic, and global-scale winds. Pollutant destinations from known emission sources can be found using a **forward trajectory** along the mean wind, while source locations of polluted air that reach receptors can be found from a **backward trajectory**.

The goal of calculating dispersion is to predict or diagnose the pollutant concentration at some point distant from the source. **Concentration** c is often measured as a mass per unit volume, such as $\mu\text{g}/\text{m}^3$. It can also be measured as volume ratio of pollutant gas to clean air, such as parts per million (**ppm**). See the Focus box for details about units.

A **source - receptor** framework is used to relate emission factors to predicted downwind concentration values. We can examine pollutants emitted at a known rate from a **point source** such as a **smoke stack**. We then follow the pollutants as they are blown downwind and mix with the surrounding air. Eventually, the mixture reaches a receptor such as a sensor, person, plant, animal or structure, where we can determine the expected concentration.

In this chapter, we will assume that the mean wind is known, based on either weather observations, or on forecasts. We will focus on the plume rise and dispersion of the pollutants, which allows us to determine the concentration of pollutants downwind of a known source.

AIR QUALITY STANDARDS

To prevent or reduce health problems associated with air pollutants, many countries set air quality standards. These standards prescribe the maximum average concentration levels in the ambient air, as allowed by law. Failure to satisfy these standards can result in fines, penalties, and increased government regulation.

In the USA, the standards are called **National Ambient Air Quality Standards (NAAQS)**. In Canada, they are called National Ambient Air Quality Objectives & Guidelines. In the Great Britain, they are called UK Air Quality Objectives. Other countries have similar names for such goals. Table 19-1 lists standards for a few countries. Governments can change these standards.

In theory, these average concentrations are not to be exceeded anywhere at ground level. In practice, meteorological events sometimes occur, such as light winds and shallow ABLs during anticyclonic conditions, that trap pollutants near the ground and cause concentration values to become undesirably large.

Also, temporary failures of air-pollution control measures at the source can cause excessive amounts of pollutants to be emitted. Regulations in some of the countries allow for a small number of concentration **exceedances** without penalty.

To avoid expensive errors during the design of new factories, smelters, or power plants, **air pollution modeling** is performed to determine the likely pollution concentration based on expected emission rates. Usually, the greatest concentrations happen near the source of pollutants. The procedures presented in this chapter illustrate how concentrations at receptors can be calculated from known emission and weather conditions.

By comparing the predicted concentrations against the air quality standards of Table 18-1, engineers can modify the factory design as needed to ensure compliance with the law. Such modifications can include building taller smoke stacks, removing the pollutant from the stack effluent, changing fuels or raw materials, or utilizing different manufacturing or chemical processes.

Table 19-1. Air quality concentration standards for the USA (US), Canada (CAN), and Great Britain (UK) for some of the commonly-regulated chemicals, as of Feb 2010. Concentrations represent averages over the time periods listed. For Canada, listed are the **maximum acceptable** levels. For UK, listed are standards for protection of human health.

Avg. Time	US	CAN	UK
Sulfur Dioxide (SO₂)			
1 yr	0.03 ppm	0.023 ppm	
1 day	0.14 ppm	0.115 ppm	125 µg/m ³
3 h	1300 µg/m ³ or 0.5 ppm		
1 h		0.334 ppm	350 µg/m ³
15 min			266 µg/m ³
Nitrogen Dioxide (NO₂)			
1 yr	100 µg/m ³ or 0.053 ppm	0.053 ppm	40 µg/m ³
1 day		0.106 ppm	
1 h	0.100 ppm	0.213 ppm	200 µg/m ³
Carbon Monoxide (CO)			
8 h	10,000 µg/m ³ or 9 ppm	13 ppm	10,000 µg/m ³
1 h	40,000 µg/m ³ or 35 ppm	31 ppm	
Ozone (O₃)			
1 yr		0.015 ppm	
1 day		0.025 ppm	
8 h	0.075 ppm	0.065 ppm	100 µg/m ³
1 h	0.12 ppm	0.082 ppm	
Fine Particulates, diameter < 10 µm (PM₁₀)			
1 yr		70 µg/m ³	40 µg/m ³
1 day	150 µg/m ³	120 µg/m ³	50 µg/m ³
Very Fine Particulates, diam. < 2.5 µm (PM_{2.5})			
1 yr	15 µg/m ³		25 µg/m ³
1 day	35 µg/m ³	30 µg/m ³	
Lead (Pb)			
1 yr			0.25 µg/m ³
3 mo	0.15 µg/m ³		
Benzene (C₆H₆)			
1 yr			3.25 µg/m ³
1,3-Butadiene (CH₂=CHCH=CH₂)			
1 yr			2.25 µg/m ³
PAH (Polycyclic Aromatic Hydrocarbons)			
1 yr			0.25 ng/m ³

Science Graffito

“If I had only one day left to live, I would live it in my statistics class — it would seem so much longer.”

– Anonymous. [from C.C Gaither (Ed.), 1996: *Statistically Speaking: A Dictionary of Quotations*, Inst. of Physics Pub., 420 pp].

Solved Example (§)

Given an x -axis aligned with the mean wind $U = 10$ m/s, and the y -axis aligned in the crosswind direction, V . Listed at right are measurements of the V -component of wind.	t (h)	V (m/s)
	0.1	2
	0.2	-1
	0.3	1
	0.4	1
	0.5	-3
a. Find the V mean wind speed and standard deviation.	0.6	-2
	0.7	0
b. If the <u>vertical</u> standard deviation is 1 m/s, is the flow isotropic?	0.8	2
	0.9	-1
	1.0	1

Solution

Given: V speeds above, $\sigma_w = 1$ m/s, $\bar{U} = 10$ m/s
 Find: $\bar{V} = ?$ m/s, $\sigma_v = ?$ m/s, isotropic (yes/no)?
 Assume V wind is constant with height.

Use eq. (19.2), except for V instead of M :

$$\bar{V}(z) = \frac{1}{N} \sum_{i=1}^N V_i(z) = (1/10) \cdot (0) = \mathbf{0 \text{ m/s}}$$

Use eq. (19.5), but for V : $\sigma_v^2 = \frac{1}{N} \sum_{k=1}^N (V_k - \bar{V})^2$
 $= (1/10) \cdot [4 + 1 + 1 + 1 + 9 + 4 + 0 + 4 + 1 + 1]$
 $= 2.6 \text{ m}^2/\text{s}^2$

Use eq. (19.6)
 $\sigma_v = [2.6 \text{ m}^2/\text{s}^2]^{1/2} = \mathbf{1.61 \text{ m/s}}$

Use eq. (19.7): ($\sigma_v = 1.61$ m/s) > ($\sigma_w = 1.0$ m/s), therefore **Anisotropic** in the y - z plane (but no info on σ_u here).

Check: Units OK. Physics OK.

Discussion: The sigma values indicate the rate of plume spread. In this example is greater spread in the crosswind direction than in the vertical direction, hence dispersion looks like the “statically stable” case plotted in Fig. 19.2. By looking at the spread of a smoke plume, you can estimate the static stability.

TURBULENCE STATISTICS

For air pollutants emitted from a point source such as the top of a smoke stack, mean wind speed and turbulence both affect the pollutant concentration measured downwind at ground level. The mean wind causes pollutant transport. Namely it blows or advects the pollutants from the source to locations downwind. However, while the plume is advecting, turbulent gusts acts to spread, or **disperse**, the pollutants as they mix with the surrounding air. Hence, we need to study both mean and turbulent characteristics of wind in order to predict downwind pollution concentrations.

Review of Basic Definitions

Recall from the Atmospheric Boundary-Layer (ABL) chapter that variables such as velocity components, temperature, and humidity can be split into mean and turbulent parts. For example:

$$M = \bar{M} + M' \tag{19.1}$$

where M is instantaneous speed in this example, \bar{M} is the mean wind speed [usually averaged over time (≈ 30 min) or horizontal distance (≈ 15 km)], and M' is the instantaneous deviation from the mean value.

The mean wind speed at any height z is

$$\bar{M}(z) = \frac{1}{N} \sum_{i=1}^N M_i(z) \tag{19.2}$$

where M_i is the wind speed measured at some time or horizontal location index i , and N is the total number of observation times or locations. Use similar definitions for mean wind components \bar{U} , \bar{V} , and \bar{W} .

Smoke plumes can spread in the vertical direction. Recall from the ABL chapter that the ABL wind speed often varies with height. Hence, the wind speed that affects the pollutant plume must be defined as an average speed over the vertical thickness of the plume.

If the wind speeds at different, equally spaced layers, between the bottom and the top of a smoke plume are known, and if k is the index of any layer, then the average over height is:

$$\bar{M} = \frac{1}{K} \sum_{k=1}^K \bar{M}(z_k) \tag{19.3}$$

where the sum is over only those layers spanned by the plume. K is the total number of layers in the plume.

This works for nearly horizontal plumes that have known vertical thickness. For the remainder of this chapter, we will use just one overbar (or sometimes no overbar) to represent an average over both time (index i), and vertical plume depth (index k).

The coordinate system is often chosen so that the x -axis is aligned with the mean wind direction, averaged over the whole smoke plume. Thus,

$$\bar{M} = \bar{U} \tag{19.4}$$

There is no lateral (crosswind) mean wind ($\bar{V} \approx 0$) in this coordinate system. The mean vertical velocity is quite small, and can usually be neglected ($\bar{W} \approx 0$, except near hills) compared to plume dispersion rates. However, $u' = U - \bar{U}$, $v' = V - \bar{V}$, and $w' = W - \bar{W}$ can be non-zero, and are all important.

Recall from the ABL chapter that **variance** σ_A^2 of any quantity A is defined as

$$\sigma_A^2 = \frac{1}{N} \sum_{k=1}^N (A_k - \bar{A})^2 = \frac{1}{N} \sum_{k=1}^N (a'^2) = \overline{a'^2} \tag{19.5}$$

The square root of the variance is the **standard deviation**:

$$\sigma_A = (\sigma_A^2)^{1/2} \tag{19.6}$$

The ABL chapter gives estimates of velocity standard deviations.

Isotropy (again)

Recall from the ABL chapter that turbulence is said to be **isotropic** when:

$$\sigma_u^2 = \sigma_v^2 = \sigma_w^2 \tag{19.7}$$

As will be shown later, the rate of smoke dispersion depends on the velocity variance. Thus, if turbulence is isotropic, then a smoke puff would tend to expand isotropically, as a sphere; namely, it would expand equally in all directions.

There are many situations where turbulence is **anisotropic** (not isotropic). During the daytime over bare land, rising thermals create stronger vertical motions than horizontal. Hence, a smoke puff would **loop** up and down and disperse more in the vertical. At night, vertical motions are very weak, while horizontal motions can be larger. This causes smoke puffs to **fan** out horizontally at night, and for other stable cases.

Similar effects operate on smoke plumes formed from continuous emissions. For this situation, only the vertical and lateral velocity variances are relevant. Fig. 19.2 illustrates how isotropy and anisotropy affect average smoke plume cross sections.

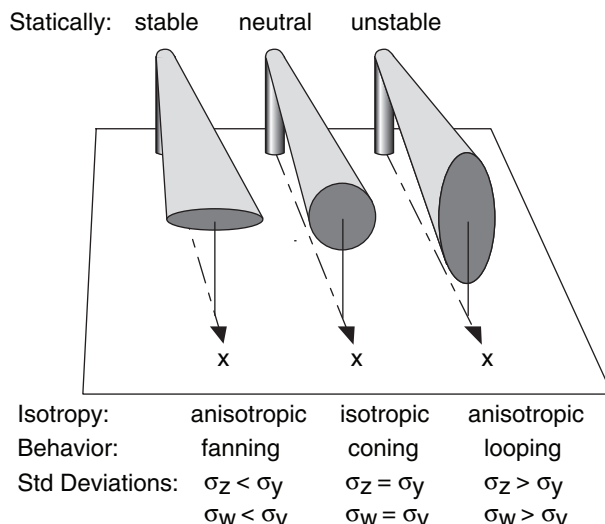

Figure 19.2
Isotropic and anisotropic dispersion of smoke plumes. The shapes of the ends of these smoke plumes are also sketched in Fig. 19.3, along the arc labeled "dispersion isotropy".

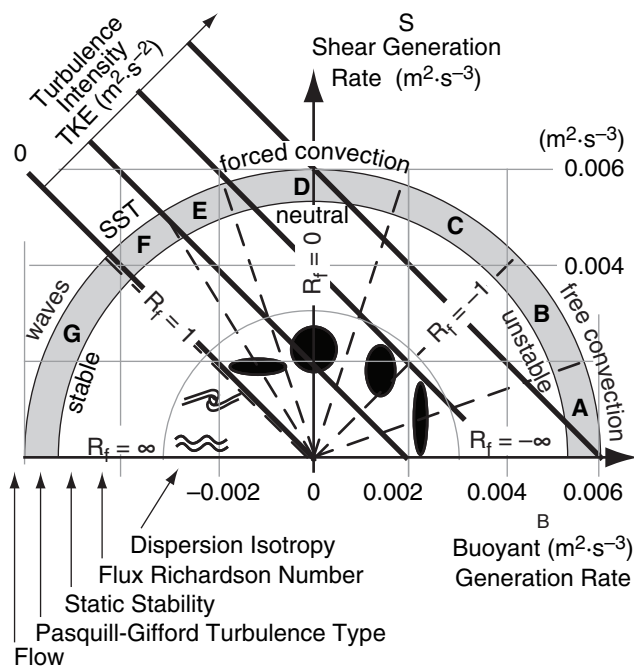

Figure 19.3
Rate of generation of TKE by buoyancy (abscissa) and shear (ordinate). Shape and rates of plume dispersion (dark spots or waves). Dashed lines separate sectors of different Pasquill-Gifford turbulence type. Isopleths of TKE intensity (dark diagonal lines). R_f is flux Richardson number. SST is stably-stratified turbulence. (See the Atmospheric Boundary Layer chapter for turbulence details.)

Table 19-2a. Pasquill-Gifford turbulence types for **Daytime**. M is wind speed at $z = 10$ m.

M (m/s)	Insolation (incoming solar radiation)		
	Strong	Moderate	Weak
< 2	A	A to B	B
2 to 3	A to B	B	C
3 to 4	B	B to C	C
4 to 6	C	C to D	D
> 6	C	D	D

Table 19-2b. Pasquill-Gifford turbulence types for **Nighttime**. M is wind speed at $z = 10$ m.

M (m/s)	Cloud Coverage	
	$\geq 4/8$ low cloud or thin overcast	$\leq 3/8$
< 2	G	G
2 to 3	E	F
3 to 4	D	E
4 to 6	D	D
> 6	D	D

Solved Example
 Determine the PG turbulence type during night with 25% cloud cover, and winds of 5 m/s.

Solution
 Given: $M = 5$ m/s, clouds = 2/8 .
 Find: PG = ?
 Use Table 18-2b. **PG = "D"**

Check: Units OK. Physics OK.
Discussion: As wind speeds increase, the PG category approaches "D" (statically neutral), for both day and night conditions. "D" implies "forced convection".

Pasquill-Gifford (PG) Turbulence Types

During weak advection, the nature of convection and turbulence are controlled by the wind speed, incoming solar radiation (**insolation**), cloud shading, and time of day or night. Pasquill and Gifford (PG) suggested a practical way to estimate the nature of turbulence, based on these forcings.

They used the letters "A" through "F" to denote different turbulence types, as sketched in Fig. 19.3 (reproduced from the ABL chapter). "A" denotes free convection in statically unstable conditions. "D" is forced convection in statically neutral conditions. Type "F" is for statically stable turbulence. Type "G" was added later to indicate the strongly statically stable conditions associated with meandering, wavy plumes in otherwise nonturbulent flow. PG turbulence types can be estimated using Tables 19-2.

Early methods for determining pollutant dispersion utilized a different plume spread equation for each Pasquill-Gifford type. One drawback is that there are only 7 discrete categories (A – G); hence, calculated plume spread would suddenly jump when the PG category changed in response to changing atmospheric conditions.

Newer air pollution models do not use the PG categories, but use the fundamental meteorological conditions (such as shear and buoyant TKE generation, or values of velocity variances that are continuous functions of wind shear and surface heating), which vary smoothly as atmospheric conditions change.

DISPERSION STATISTICS

Snapshot vs. Average

Snapshots of smoke plumes are similar to what you see with your eye. The plumes have fairly-well defined edges, but each plume wiggles up and down, left and right (Fig. 19.4a). The concentration c through such an instantaneous smoke plume can be quite variable, so a hypothetical vertical profile is sketched in Fig. 19.4a.

A time exposure of a smoke-stack plume might appear as sketched in Fig. 19.4b. When averaged over a time interval such as an hour, most of the pollutants are found near the centerline of the plume. Average concentration decreases smoothly with distance away from the centerline. The resulting profile of concentration is often bell shaped, or Gaussian. Air quality standards in most countries are based on averages, as was listed in Table 18-1.

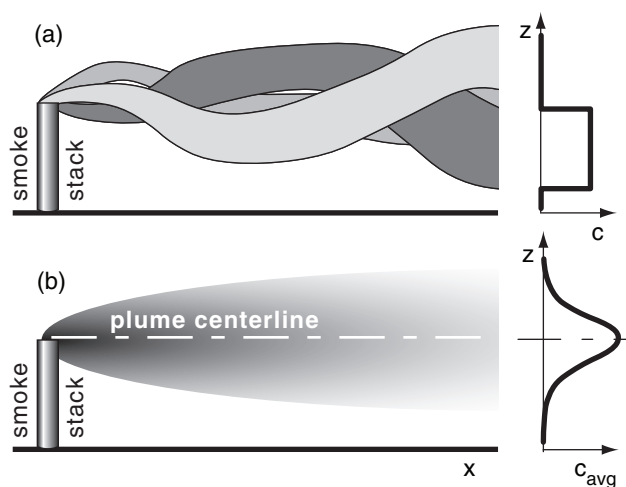

Figure 19.4
 (a) Snapshots showing an instantaneous smoke plume at different times, also showing a concentration c profile for the dark-shaded plume. (b) Average over many plumes, with the average concentration c_{avg} profile shown at right.

Center of Mass

The **plume centerline** height z_{CL} can be defined as the location of the **center of mass** of pollutants. In other words, it is the average height of the pollutants. Suppose you measure the concentration c_k of pollutants at a range of equally-spaced heights z_k through the smoke plume. The center of mass is a weighted average defined by:

$$z_{CL} = \bar{z} = \frac{\sum_{k=1}^K c_k \cdot z_k}{\sum_{k=1}^K c_k} \quad \bullet(19.8)$$

where K is the total number of heights, and k is the height index, and the overbar denotes a mean.

For passive tracers with slow exit velocity from the stack, the plume centerline is at the same height as the top of the stack. For buoyant plumes in hot exhaust gases, and for smoke blown at high speed out of the top of the stack, the centerline rises above the top of the stack.

A similar center of mass can be found for the crosswind (lateral) location, assuming measurements are made at equal intervals across the plume. Passive tracers blow downwind. Thus, the center of mass of a smoke plume, when viewed from above such as from a satellite, follows a mean wind trajectory from the stack location (see the discussion of streamlines, streaklines, and trajectories in the Local Winds chapter).

Standard Deviation – Sigma

For time-average plumes such as in Figs. 19.4b and 19.5, the plume edges are not easy to locate. They are poorly defined because the bell curve gradually approaches zero concentration with increasing distance from the centerline. Thus, we cannot use edges to measure plume spread (depth or width).

Instead, the standard deviation σ_z of pollutant location is used as a measure of plume spread, where standard deviation is the square root of the variance σ_z^2 . The vertical-position deviations must be weighted by the pollution concentration to find sigma, as shown here:

$$\sigma_z = \left[\frac{\sum_{k=1}^K c_k \cdot (z_k - \bar{z})^2}{\sum_{k=1}^K c_k} \right]^{1/2} \quad \bullet(19.9)$$

where $\bar{z} = z_{CL}$ is the average height found from the previous equation.

A similar equation can be defined for lateral standard deviation σ_y . The vertical and lateral dis-

ON DOING SCI. • Data Misinterpretation

Incomplete data can be misinterpreted, leading to expensive erroneous conclusions. Suppose an air-pollution meteorologist/engineer erects a tall tower at the site of a proposed 75 m high smoke stack. On this tower are electronic thermometers at two heights: 50 and 100 m. On many days, these measurements give temperatures that are on the same adiabat (Fig. a).

Regarding static stability, one interpretation (Fig. b) is that the atmosphere is statically neutral. Another interpretation (Fig. c) is that it is a statically unstable convective mixed layer. If neutral stability is erroneously noted on a day of static instability, then the corresponding predictions of dispersion rate and concentrations will be embarrassingly wrong.

To resolve this dilemma, the meteorologist/engineer needs additional info. Either add a third thermometer near the ground, or add a net radiation sensor, or utilize manual observations of sun, clouds, and wind to better determine the static stability.

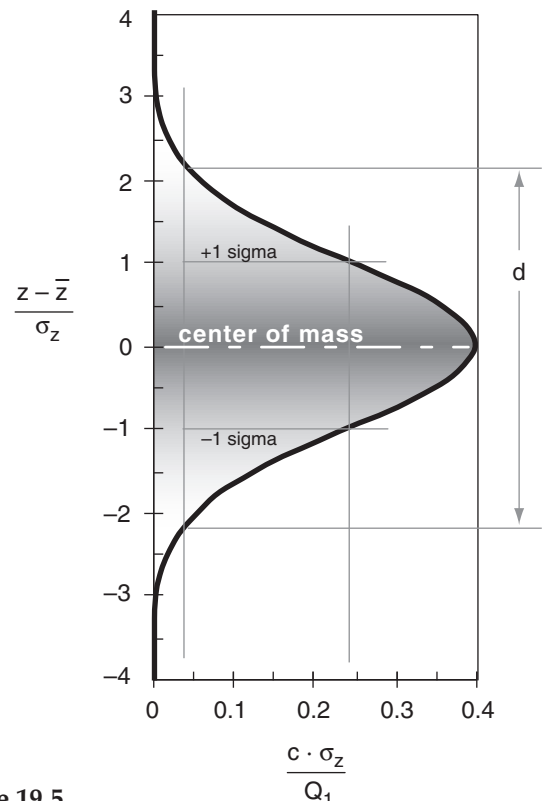
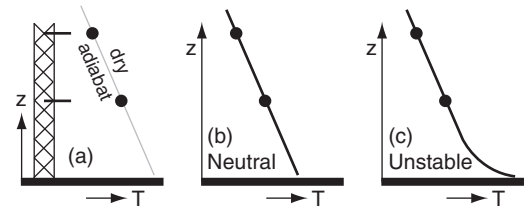

Figure 19.5
Gaussian curve.
Each unit along the ordinate corresponds to one standard deviation away from the center. Nominal 1-D plume width is d .

Solved Example (§)

Given the following 1-D concentration measurements.

z (km)	c ($\mu\text{g}/\text{m}$)
2.0	0
1.8	1
1.6	3
1.4	5
1.2	7
1.0	6
0.8	2
0.6	1
0.4	0
0.2	0
0.0	0

Solution

Given: $\Delta z = 0.2$ km, with concentrations above
 Find: $\bar{z} = ?$ km, $\sigma_z = ?$ km, $Q_1 = ?$ km $\cdot\mu\text{g}/\text{m}$,
 $d = ?$ km, and plot $c(z) = ?$ $\mu\text{g}/\text{m}$

Use eq. (19.8) to find the plume centerline height:
 $\bar{z} = (30.2 \text{ km}\cdot\mu\text{g}\cdot\text{m}^{-1}) / (25 \mu\text{g}\cdot\text{m}^{-1}) = \mathbf{1.208 \text{ km}}$

Use eq. (19.9):
 $\sigma_z^2 = (1.9575 \text{ km}^2\cdot\mu\text{g}\cdot\text{m}^{-1}) / (25 \mu\text{g}\cdot\text{m}^{-1}) = 0.0783 \text{ km}^2$
 $\sigma_z = [\sigma_z^2]^{1/2} = [0.0783 \text{ km}^2]^{1/2} = \mathbf{0.28 \text{ km}}$

Use eq. (19.12):
 $d = 4.3 \cdot (0.28 \text{ km}) = \mathbf{1.2 \text{ km}}$

Use eq. (19.11):
 $Q_1 = (0.2 \text{ km}) \cdot (25 \mu\text{g}\cdot\text{m}^{-1}) = \mathbf{5.0 \text{ km}\cdot\mu\text{g}/\text{m}}$

Use eq. (19.10) to plot the best-fit curve:

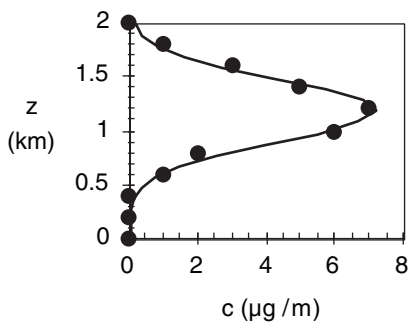

Check: Units OK. Physics OK. Sketch OK.

Discussion: The curve is a good fit to the data. Often the measured data will have some scatter due to the difficulty of making concentration measurements, but the equations in this section are able to find the best-fit curve. This statistical curve-fitting method is called the **method of moments**, because we matched the first two statistical moments (mean & variance) of the Gaussian distribution to the corresponding moments calculated from the data.

persion need not be equal, because the dispersive nature of turbulence is not the same in the vertical and horizontal when turbulence is anisotropic.

When the plume is compact, the standard deviation and variance are small. These statistics increase as the plume spreads. Hence we expect sigma to increase with distance downwind of the stack. Such spread will be quantified in the next main section.

Gaussian Curve

The **Gaussian** or “normal” curve is bell shaped, and is given in one-dimension (1-D) by:

$$c(z) = \frac{Q_1}{\sigma_z \sqrt{2\pi}} \cdot \exp \left\{ -0.5 \left[\frac{z - \bar{z}}{\sigma_z} \right]^2 \right\} \quad \bullet(19.10)$$

where $c(z)$ is the one-dimensional concentration (g/m) at any height z , and Q_1 (g) is the total amount of pollutant emitted.

This curve is symmetric about the mean location, and has tails that asymptotically approach zero as z approaches infinity (Fig. 19.5). The area under the curve is equal to Q_1 , which physically means that pollutants are conserved. The **inflection points** in the curve (points where the curve changes from concave left to concave right) occur at exactly one σ_z from the mean. Between $\pm 2\sigma_z$ are 95% of the pollutants; hence, the Gaussian curve exhibits strong central tendency.

Eq. (19.10) has three parameters: Q_1 , \bar{z} , and σ_z . These parameters can be estimated from measurements of concentration at equally-spaced heights through the plume, in order to find the best-fit Gaussian curve. The last two parameters are found with eqs. (19.8) and (19.9). The first parameter is found from:

$$Q_1 = \Delta z \cdot \sum_{k=1}^K c_k \quad \bullet(19.11)$$

where Δz is the height interval between neighboring measurements.

Nominal Plume Edge

For practical purposes, the edge of a Gaussian plume is defined as the location where the concentration is 10% of the centerline concentration. This gives a plume spread (e.g., depth from top edge to bottom edge) of

$$d \approx 4.3 \cdot \sigma_z \quad \bullet(19.12)$$

TAYLOR'S STATISTICAL THEORY

Statistical theory explains how plume dispersion statistics depend on turbulence statistics and downwind distance.

Passive Conservative Tracers

Many pollutants consist of gases or very fine particles. They passively ride along with the wind, and trace out the air motion. Hence, the rate of dispersion depends solely on the air motion (wind and turbulence) and not on the nature of the pollutant. These are called **passive tracers**. If they also do not decay, react, fall out, or stick to the ground, then they are also called **conservative tracers**, because all pollutant mass emitted into the air is conserved.

Some pollutants are not passive or conservative. Dark soot particles can adsorb sunlight to heat the air, but otherwise they might not be lost from the air. Thus, they are active because they alter turbulence by adding buoyancy, but are conservative. Radioactive pollutants are both nonconservative and active, due to radioactive decay and heating.

For passive conservative tracers, the amount of dispersion (σ_y or σ_z) depends not only on the intensity of turbulence (σ_v or σ_w , see the ABL chapter), but on the distribution of turbulence energy among eddies of different sizes. For a plume of given spread, eddies as large as the plume diameter cause much greater dispersion than smaller-size eddies. Thus, dispersion rate increases with time or downwind distance, as shown below.

Dispersion Equation

G.I. Taylor theoretically examined an individual passive tracer particle as it moved about by the wind. Such an approach is **Lagrangian**, as discussed in the Heat chapter. By averaging over many such particles within a smoke cloud, he derived a statistical theory for turbulence.

One approximation to his result is

$$\sigma_y^2 = 2 \cdot \sigma_v^2 \cdot t_L^2 \cdot \left[\frac{x}{M \cdot t_L} - 1 + \exp\left(-\frac{x}{M \cdot t_L}\right) \right] \tag{19.13a}$$

$$\sigma_z^2 = 2 \cdot \sigma_w^2 \cdot t_L^2 \cdot \left[\frac{x}{M \cdot t_L} - 1 + \exp\left(-\frac{x}{M \cdot t_L}\right) \right] \tag{19.13b}$$

where x is distance downwind from the source, M is wind speed, and t_L is the Lagrangian time scale.

BEYOND ALGEBRA • Diffusion Equation

The Gaussian concentration distribution is a solution to the diffusion equation, as is shown here.

For a conservative, passive tracer, the budget equation says that concentration c in a volume will increase with time t if greater tracer flux F_c enters a volume than leaves. In one dimension (z), this is:

$$\frac{dc}{dt} = -\frac{\partial F_c}{\partial z} \tag{a}$$

If turbulence consists of only small eddies, then turbulent flux of tracer flows down the mean tracer gradient:

$$F_c = -K \frac{\partial c}{\partial z} \tag{b}$$

where K , the eddy diffusivity, is analogous to a molecular diffusivity (see K-Theory in the Atmospheric Boundary Layer chapter), and F_c is in kinematic units (concentration times velocity).

Plugging eq. (b) into (a), and assuming constant K , gives the 1-D **diffusion equation**:

$$\frac{dc}{dt} = K \frac{\partial^2 c}{\partial z^2} \tag{c}$$

This parabolic differential equation can be solved with initial conditions (IC) and boundary conditions (BC). Suppose a smoke puff of mass Q grams of tracer is released in the middle of a vertical pipe that is otherwise filled with clean air at time $t = 0$. Define the vertical coordinate system so that $z = 0$ at the initial puff height (and $\bar{z} = 0$). Dispersion up and down the pipe is one-dimensional.

IC: $c = 0$ at $t = 0$ everywhere except at $z = 0$.

BC1: $\int c \, dz = Q$, at all t , where integration is $-\infty$ to ∞

BC2: c approaches 0 as z approaches $\pm \infty$, at all t .

The solution is:

$$c = \frac{Q}{(4\pi Kt)^{1/2}} \exp\left(-\frac{z^2}{4Kt}\right) \tag{d}$$

You can confirm that this is a solution by plugging it into eq. (c), and checking that the LHS equals the RHS. It also satisfies all initial & boundary conditions.

Comparing eq. (d) with eq. (19.10), we can identify the standard deviation of height as

$$\sigma_z = \sqrt{2Kt} \tag{e}$$

which says that tracer spread increases with the square root of time, and greater eddy-diffusivity causes faster spread rate. Thus, the solution is Gaussian:

$$c = \frac{Q}{\sqrt{2\pi} \cdot \sigma_z} \exp\left[-\frac{1}{2} \left(\frac{z}{\sigma_z}\right)^2\right] \tag{19.10}$$

Finally, using **Taylor's hypothesis** that $t = x/M$, we can compare eq. (e) with the σ_z version of eq. (19.15), and conclude that:

$$K = \sigma_w^2 \cdot t_L \tag{f}$$

showing how K increases with turbulence intensity.

Solved Example (§)

Plot vertical and horizontal plume spread σ_z and σ_y vs. downwind distance x , using a Lagrangian time scale of 1 minute and wind speed of 10 m/s at height 100 m in a neutral boundary layer of depth 500 m. There is a rough surface of varied crops.

- a) Plot on both linear and log-log graphs.
- b) Also plot the short and long-distance limits of σ_y on the log-log graph.

Solution

Given: $z = 100$ m, $M = 10$ m/s, $t_L = 60$ s, $h = 500$ m
 Find: σ_z and σ_y (m) vs. x (km).

Refer to Boundary Layer chapter to calculate the info needed in the eqs. for Taylor's statistical theory. Use Table 18-1 for rough surface of varied crops: aerodynamic roughness length is $z_o = 0.25$ m. Use this z_o in eq. (18.13) to get the friction velocity: $u_* = [0.4 \cdot (10 \text{ m/s})] / \ln(100 \text{ m} / 0.25 \text{ m}) = 0.668$ m/s. Use this u_* in eq. (18.25b) to get the velocity variance $\sigma_v = 1.6 \cdot (0.668 \text{ m/s}) \cdot [1 - 0.5 \cdot (100 \text{ m} / 500 \text{ m})] = 0.96$ m/s. Similarly, use eq. (18.25c): $\sigma_w = 0.75$ m/s.

Use σ_v and σ_w in eqs. (19.13a & b) in a spreadsheet to calculate σ_y and σ_z , and plot the results on graphs:

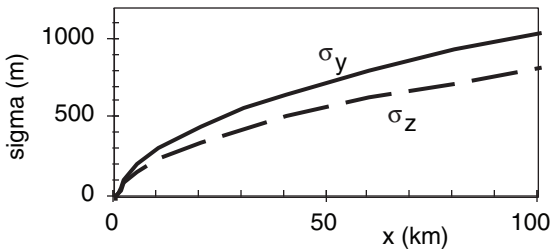

A linear graph is shown above, and log-log below.

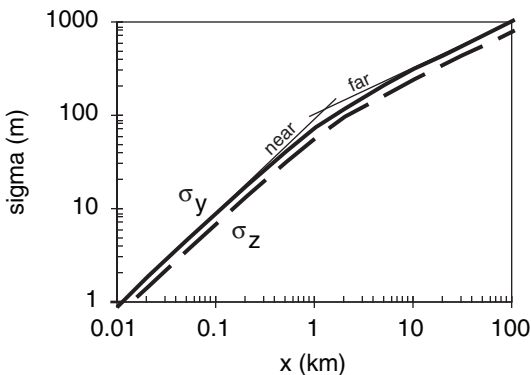

Eqs. (19.14) & (19.15) for the near and far approximations are plotted as the thin solid lines.

Check: Units OK. Physics OK. Sketch OK.

Discussion: Plume spread increases with distance downwind of the smoke stack. $\sigma_y \approx \sigma_z$ at any x , giving the nearly isotropic dispersion expected for statically neutral air. The cross-over between short and long time limits is at $x \approx 2 \cdot M \cdot t_L = 1.2$ km.

Thus, the spread (σ_y and σ_z) of passive tracers increases with turbulence intensity (σ_v and σ_w) and with downwind distance x .

The **Lagrangian time scale** is a measure of how quickly a variable becomes uncorrelated with itself. For very small-scale atmospheric eddies, this time scale is only about 15 seconds. For convective thermals, it is on the order of 15 minutes. For the synoptic-scale high and low pressure systems, the Lagrangian time scale is on the order of a couple days. We will often use a value of $t_L \approx 1$ minute for dispersion in the boundary layer.

Dispersion Near & Far from the Source

Close to the source (at small times after the start of dispersion), eq. (19.13a) reduces to

$$\sigma_y \approx \sigma_v \cdot \left(\frac{x}{M} \right) \quad \bullet(19.14)$$

while far from the source it can be approximated by:

$$\sigma_y \approx \sigma_v \cdot \left(2 \cdot t_L \cdot \frac{x}{M} \right)^{1/2} \quad \bullet(19.15)$$

There are similar equations for σ_z as a function of σ_w .

Thus, we expect plumes to initially spread linearly with distance near to the source, but change to square-root with distance further downwind.

DISPERSION IN NEUTRAL & STABLE BOUNDARY LAYERS

To calculate pollutant concentration at the surface, one needs to know both the height of the plume centerline, and the spread of pollutants about that centerline. **Plume rise** is the name given to the first issue. **Dispersion** (from Taylor's statistical theory) is the second. When they are both used in an expression for the average spatial distribution of pollutants, pollution concentrations can be calculated.

Plume Rise

Ground-level concentration generally decreases as plume-centerline height increases. Hence, plume rise above the physical stack top is often desirable. The centerline of plumes can rise above the stack top due to the initial momentum associated with exit velocity out of the top of the stack, and due to buoyancy if the effluent is hot.

Neutral Boundary Layers

Statically neutral situations are found in the residual layer (not touching the ground) during light winds at night. They are also found throughout the bottom of the boundary layer (touching the ground) on windy, overcast days or nights.

The height z_{CL} of the plume centerline above the ground in neutral boundary layers is:

$$z_{CL} = z_s + \left[a \cdot l_m^2 \cdot x + b \cdot l_b \cdot x^2 \right]^{1/3} \quad \bullet(19.16)$$

where $a = 8.3$ (dimensionless), $b = 4.2$ (dimensionless), x is distance downwind of the stack, and z_s is the physical stack height. This equation shows that the plume centerline keeps rising as distance from the stack increases. It ignores the capping inversion at the ABL top, which would eventually act like a lid on plume rise and upward spread.

A momentum length scale, l_m is defined as:

$$l_m \approx \frac{W_o \cdot R_o}{M} \quad \bullet(19.17)$$

where R_o is the stack-top radius, W_o is stack-top exit velocity of the effluent, and M is the ambient wind speed at stack top. l_m can be interpreted as a ratio of vertical emitted momentum to horizontal wind momentum.

A buoyancy length scale, l_b is defined as:

$$l_b \approx \frac{W_o \cdot R_o^2 \cdot |g| \cdot \Delta\theta}{M^3 \cdot \theta_a} \quad \bullet(19.18)$$

where $|g| = 9.8 \text{ m/s}^2$ is gravitational acceleration magnitude, $\Delta\theta = \theta_p - \theta_a$ is the temperature excess of the effluent, θ_p is the initial stack gas potential temperature at stack top, and θ_a is the ambient potential temperature at stack top. l_b can be interpreted as a ratio of vertical buoyancy power to horizontal power of the ambient wind.

Stable Boundary Layers

In statically stable situations, the ambient potential temperature increases with height. This limits the plume-rise centerline to a final equilibrium height z_{CLEq} above the ground:

$$z_{CLEq} = z_s + 2.6 \cdot \left(\frac{l_b \cdot M^2}{N_{BV}^2} \right)^{1/3} \quad \bullet(19.19)$$

where the Brunt-Väisälä frequency N_{BV} is used as a measure of static stability (see the Stability chapter).

Solved Example (§)

At stack top, effluent velocity is 20 m/s, temperature is 200°C, emission rate is 250 g/s of SO₂. The stack is 75 m high, and has a radius of 2 m at the top. At stack top, the ambient wind is 5 m/s, and ambient potential temperature is 20°C. For a neutral boundary layer, plot plume centerline height vs. downwind distance.

Solution

Given: $W_o = 20 \text{ m/s}$, $Q = 250 \text{ g/s}$, $z_s = 75 \text{ m}$, $M = 5 \text{ m/s}$
 $\theta_p = 473\text{K} + (9.8\text{K/km}) \cdot (0.075 \text{ km}) = 474 \text{ K}$, $\theta_a = 293 \text{ K}$
 Find: $z_{CL}(x) = ? \text{ m}$.

Use eq. (19.17): $l_m = (20\text{m/s}) \cdot (2\text{m}) / (5\text{m/s}) = 8 \text{ m}$

Use eq. (19.18):

$$l_b \approx \frac{(20\text{m/s}) \cdot (2\text{m})^2 \cdot (9.8\text{m}\cdot\text{s}^{-2})}{(5\text{m/s})^3} \cdot \frac{(474 - 293\text{K})}{293\text{K}} = 3.87 \text{ m}$$

Use eq. (19.16):

$$z_{CL} = (75\text{m}) + \left[8.3 \cdot (8\text{m})^2 \cdot x + 4.2 \cdot (3.87\text{m}) \cdot x^2 \right]^{1/3}$$

This is shown as the solid line on the plot below:

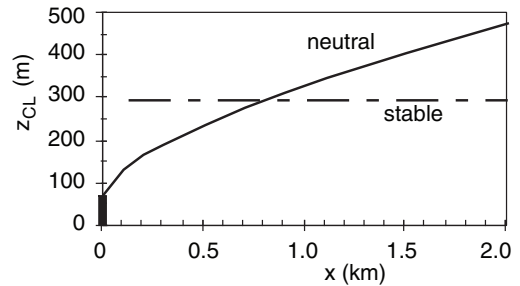

Check: Units OK. Physics OK. Sketch OK.

Discussion: In neutral conditions, the plume continues to rise with downwind distance. However, real plumes usually hit an elevated inversion & stop rising. Use a thermo diagram to locate the inversions aloft.

Solved Example

Same as previous example, but for a stable boundary layer with $\Delta\theta_a/\Delta z = 5^\circ\text{C}/\text{km}$. Find z_{CLEq} .

Solution

Given: $W_o = 20 \text{ m/s}$, $Q = 250 \text{ g/s}$, $z_s = 75 \text{ m}$, $M = 5 \text{ m/s}$
 $\theta_p = 474 \text{ K}$, $\theta_a = 293 \text{ K}$, $\Delta\theta_a/\Delta z = 5^\circ\text{C}/\text{km}$
 Find: $\Delta z_{CLEq} = ? \text{ m}$, then plot z_{CLEq} vs. x

Use eq. (5.4b) to find the Brunt-Väisälä frequency²:

$$N_{BV}^2 = [(9.8\text{m}\cdot\text{s}^{-2})/293\text{K}] \cdot [5\text{K}/1000\text{m}] = 1.67 \times 10^{-4} \text{ s}^{-2}$$

Use eq. (19.19):

$$z_{CLEq} = (75\text{m}) + 2.6 \cdot \left(\frac{(3.87\text{m}) \cdot (5\text{m/s})^2}{1.67 \times 10^{-4} \text{ s}^{-2}} \right)^{1/3}$$

$z_{CLEq} = z_s + \Delta z_{CLEq} = 75 \text{ m} + 216.7 \text{ m} = \mathbf{291.75 \text{ m}}$
 See dashed line in the previous solved example.

Check: Units OK. Physics OK. Sketch OK.

Discussion: The actual plume centerline does not reach the equilibrium height instantly. Instead, it approaches it a bit slower than the neutral plume rise curve plotted in the previous solved ex.

Solved Example (§)

Given a “surface” wind speed of 10 m/s at 10 m above ground, neutral static stability, boundary layer depth 800 m, surface roughness length 0.1 m, emission rate of 300 g/s of passive, non-buoyant SO₂, wind speed of 20 m/s at plume centerline height, and Lagrangian time scale of 1 minute.

Plot isopleths of concentration at the ground for plume centerline heights of: (a) 100m, (b) 200m

Solution

Given: $M = 10$ m/s at $z = 10$ m, $z_0 = 0.1$ m,
 $M = 20$ m/s at $z = 100$ m = z_{CL} , neutral,
 $Q = 300$ g/s of SO₂, $t_L = 60$ s, $h = 800$ m
 Find: c (μg/m³) vs. x (km) and y (km), at $z = 0$.
 Assume z_{CL} is constant.

Use eq. (18.13) from the Boundary Layer (BL) chapter:
 $u_* = 0.4 \cdot (10 \text{ m/s}) / \ln(10 \text{ m}/0.1 \text{ m}) = 0.869 \text{ m/s}$

(a) Use eqs. (18.25b) & (18.25c) from the BL chapter:
 $\sigma_y = 1.6 \cdot (0.869 \text{ m/s}) \cdot [1 - 0.5(100/800)] = 1.3 \text{ m/s}$
 $\sigma_w = 1.25 \cdot (0.869 \text{ m/s}) \cdot [1 - 0.5(100/800)] = 1.02 \text{ m/s}$

Use eq. (19.13a & b) in a spreadsheet to get σ_y and σ_z vs. x . Then use eq. (19.21) to find c at each x and y :

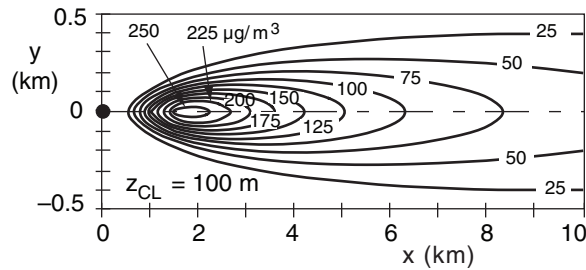

(b) Similarly, for a higher plume centerline:

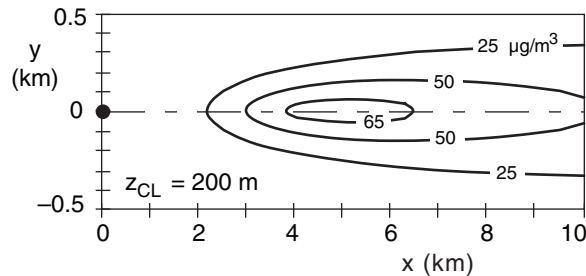

Check: Units OK. Physics OK.

Discussion: These plots show the pollutant **footprints**. Higher plume centerlines cause lower concentrations at the ground. That is why engineers design tall smoke stacks, and try to enhance buoyant plume rise.

Faster wind speeds also cause more dilution. Because faster winds are often found at higher altitudes, this also favors tall stacks for reducing surface concentrations.

Gaussian Concentration Distribution

For neutral and stable boundary layers (PG types C through F), the sizes of turbulent eddies are relatively small compared to the depth of the boundary layer. This simplifies the problem by allowing turbulent dispersion to be modeled analogous to molecular diffusion. For this situation, the average concentration distribution about the plume centerline is well approximated by a 3-D Gaussian bell curve:

$$c = \frac{Q}{2\pi\sigma_y\sigma_zM} \cdot \exp\left[-0.5 \cdot \left(\frac{y}{\sigma_y}\right)^2\right] \cdot \left\{ \exp\left[-0.5 \cdot \left(\frac{z - z_{CL}}{\sigma_z}\right)^2\right] + \exp\left[-0.5 \cdot \left(\frac{z + z_{CL}}{\sigma_z}\right)^2\right] \right\} \quad \bullet(19.20)$$

where Q is the source emission rate of pollutant (g/s), σ_y and σ_z are the plume-spread standard deviations in the crosswind and vertical, y is lateral (crosswind) distance of the receptor from the plume centerline, z is vertical distance of the receptor above ground, z_{CL} is the height of the plume centerline above the ground, and M is average ambient wind speed at the plume centerline height.

For receptors at the ground ($z = 0$), eq. (19.20) reduces to:

$$c = \frac{Q}{\pi\sigma_y\sigma_zM} \cdot \exp\left[-0.5 \cdot \left(\frac{y}{\sigma_y}\right)^2\right] \cdot \exp\left[-0.5 \cdot \left(\frac{z_{CL}}{\sigma_z}\right)^2\right] \quad \bullet(19.21)$$

The pattern of concentration at the ground is called a **footprint**.

The above two equations assume that the ground is flat, and that pollutants that hit the ground are “reflected” back into the air. Also, they do not work for dispersion in statically unstable mixed layers.

To use these equations, the turbulent velocity variances σ_v^2 and σ_w^2 are first found from the equations in the Boundary Layer chapter. Next, plume spread σ_y and σ_z is found from Taylor’s statistical theory (eqs. 19.13). Plume centerline heights z_{CL} are then found from the previous subsection. Finally, they are all used in eqs. (19.20) or (19.21) to find the concentration at a receptor.

Recall that Taylor’s statistical theory states that the plume spread increases with downwind distance. Thus, σ_y , σ_z , and z_{CL} are functions of x , which makes concentration c a strong function of x , in spite of the fact that x does not appear explicitly in the two equations above.

DISPERSION IN UNSTABLE BOUNDARY LAYERS (CONVECTIVE MIXED LAYERS)

During conditions of light winds over an underlying warmer surface (PG types A & B), the boundary layer is **statically unstable** and in a state of **free convection**. Turbulence consists of thermals of warm air that rise from the surface to the top of the mixed layer. These vigorous updrafts are surrounded by broader areas of weaker downdraft. The presence of such large turbulent structures and their asymmetry causes dispersion behavior that differs from the usual Gaussian plume dispersion.

As smoke is emitted from a point source such as a smoke stack, some of the emissions are by chance emitted into the updrafts of passing thermals, and some into downdrafts. Thus, the smoke appears to **loop** up and down, as viewed in a snapshot. However, when averaged over many thermals, the smoke disperses in a unique way that can be described deterministically. This description works only if variables are normalized by free-convection scales.

The first step is to get the meteorological conditions such as wind speed, ABL depth, and surface heat flux. These are then used to define the ABL convective scales such as the Deardorff velocity w_* . Source emission height, and downwind receptor distance are then normalized by the convective scales to make dimensionless distance variables.

Next, the dimensionless (normalized) variables are used to calculate the plume centerline height and vertical dispersion distance. These are then used as a first guess in a Gaussian equation for crosswind-integrated concentration distribution, which is a function of height in the ABL. By dividing each distribution by the sum over all distributions, a corrected cross-wind-integrated concentration can be found that has the desirable characteristic of conserving pollutant mass.

Finally, the lateral dispersion distance is estimated. It is used with the cross-wind-integrated concentration to determine the dimensionless Gaussian concentration at any lateral distance from the plume centerline. Finally, the dimensionless concentration can be converted into a dimensional concentration using the meteorological scaling variables.

Although this procedure is complex, it is necessary, because non-local dispersion by large convective circulations in the unstable boundary layer works completely differently than the small-eddy dispersion in neutral and stable ABLs. The whole procedure can be solved on a spreadsheet, which was used to produce Figs. 19.7 and 19.8.

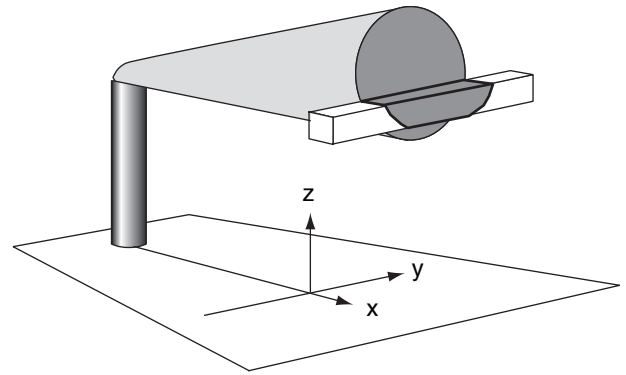

Figure 19.6

Crosswind integrated concentration c_y is the total amount of pollutants in a thin conceptual box (1 m^2 at the end) that extends crosswind (y -direction) across the smoke plume. This concentration is a function of only x and z .

Relevant Variables

Physical Variables:

c = concentration of pollutant (g/m^3)

c_y = **crosswind-integrated concentration** (g/m^2), which is the total amount of pollutant within a long-thin box that is 1 m^2 on each end, and which extends laterally across the plume at any height z and downwind location x (see Fig. 19.6)

Q = emission rate of pollutant (g/s)

x = distance of a receptor downwind of the stack (m)

z = height of a receptor above ground (m)

z_{CL} = height of the plume centerline (center of mass) above the ground (m)

z_s = source height (m) after plume-induced rise

σ_y = lateral standard deviation of pollutant (m)

σ_z = vertical standard deviation of pollutant (m)

σ_{z_c} = vertical standard deviation of crosswind-integrated concentration of pollutant (m)

Mixed-Layer Scaling Variables:

F_H = effective surface kinematic heat flux ($\text{K}\cdot\text{m}/\text{s}$), see Surface Fluxes section of Heat chapter.

M = mean wind speed (m/s)

$$w_* = \left[\frac{|g| \cdot z_i \cdot F_H}{T_v} \right]^{1/3} = \text{Deardorff velocity (m/s)} \quad (19.22)$$

$\approx 0.08 \cdot w_B$, where w_B is the buoyancy velocity.

z_i = depth of the convective mixed layer (m)

Dimensionless Scales:

These are usually denoted by uppercase symbols (except for M and Q , which have dimensions).

$$C = \frac{c \cdot z_i^2 \cdot M}{Q} = \text{dimensionless concentration} \quad (19.23)$$

$$C_y = \frac{c_y \cdot z_i \cdot M}{Q} = \text{dimensionless crosswind-integrated concentration} \quad (19.24)$$

$$X = \frac{x \cdot w_*}{z_i \cdot M} = \text{dimensionless downwind distance of receptor from source} \quad (19.25)$$

$$Y = y / z_i = \text{dimensionless crosswind (lateral) distance of receptor from centerline} \quad (19.26)$$

$$Z = z / z_i = \text{dimensionless receptor height} \quad (19.27)$$

$$Z_{CL} = z_{CL} / z_i = \text{dimensionless plume centerline height} \quad (19.28)$$

$$Z_s = z_s / z_i = \text{dimensionless source height} \quad (19.29)$$

$$\sigma_{yd} = \sigma_y / z_i = \text{dimensionless lateral standard deviation} \quad (19.30)$$

$$\sigma_{zdc} = \sigma_{zc} / z_i = \text{dimensionless vertical standard deviation of crosswind-integrated concentration} \quad (19.31)$$

As stated in more detail earlier, to find the pollutant concentration downwind of a source during convective conditions, three steps are used: (1) Find the plume centerline height. (2) Find the crosswind integrated concentration at the desired x and z location. (3) Find the actual concentration at the desired y location.

Plume Centerline

For neutrally-buoyant emissions, the dimensionless height of the center of mass (= centerline Z_{CL}) varies with dimensionless distance downwind X :

$$Z_{CL} \approx 0.5 + \frac{0.5}{1 + 0.5 \cdot X^2} \cdot \cos \left[2\pi \frac{X}{\lambda} + \cos^{-1}(2 \cdot Z_s - 1) \right] \quad (19.32)$$

where Z_s is the dimensionless source height, and the dimensionless wavelength parameter is $\lambda = 4$.

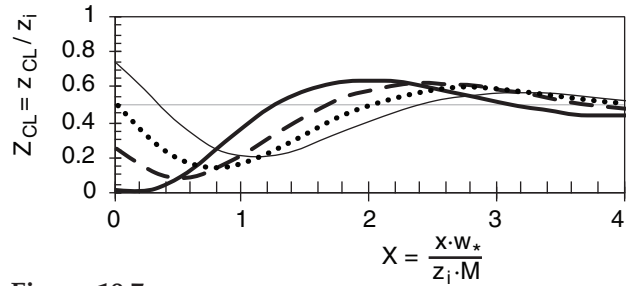

Figure 19.7
Height of the averaged pollutant centerline z_{CL} with downwind distance x , normalized by mixed-layer scales. Dimensionless source heights are $Z_s = z_s/z_i = 0.025$ (thick solid line); 0.25 (dashed); 0.5 (dotted); and 0.75 (thin solid). The plume is neutrally buoyant.

The centerline tends to move down from elevated sources, which can cause high concentrations at ground level (see Fig. 19.7). Then further downwind, they rise a bit higher than half the mixed-layer depth, before reaching a final height at $0.5 \cdot z_i$. For buoyant plumes, the initial downward movement of the centerline is much weaker, or does not occur.

Crosswind Integrated Concentration

The following algorithm provides a quick approximation for the crosswind integrated concentration. Find a first guess dimensionless C_y' as a function of dimensionless height Z using a Gaussian approach for vertical dispersion:

$$C_y' = \exp \left[-0.5 \cdot \left(\frac{Z - Z_{CL}}{\sigma_{zdc}} \right)^2 \right] \quad (19.33)$$

where the prime denotes a first guess, and where the vertical dispersion distance is:

$$\sigma_{zdc}' = a \cdot X \quad (19.34)$$

with $a = 0.25$. This calculation is done at K equally-spaced heights between the ground to the top of the mixed layer.

Next, find the average over all heights $0 \leq Z \leq 1$:

$$\overline{C_y'} = \frac{1}{K} \sum_{k=1}^K C_y' \quad (19.35)$$

where index k corresponds to height z . Finally, calculate the revised estimate for dimensionless crosswind integrated concentration at any height:

$$C_y = C_y' / \overline{C_y'} \quad (19.36)$$

Examples are plotted in Fig. 19.8 for various source heights.

Concentration

The final step is to assume that lateral dispersion is Gaussian, according to:

$$C = \frac{C_y}{(2\pi)^{1/2} \cdot \sigma_{yd}} \exp \left[-0.5 \cdot \left(\frac{Y}{\sigma_{yd}} \right)^2 \right] \quad \bullet(19.37)$$

The dimensionless standard deviation of lateral dispersion distance from an elevated source is

$$\sigma_{yd} \approx b \cdot X \quad (19.38)$$

where $b = 0.5$.

At large downwind distances (i.e., at $X \geq 4$), the dimensionless crosswind integrated concentration always approaches $C_y \rightarrow 1.0$, at all heights. Also, directly beneath the plume centerline, $Y = 0$.

SUMMARY

Pollutants emitted from a smoke stack will blow downwind and disperse by turbulent mixing with ambient air. By designing a stack of sufficient height, pollutants at ground level become sufficiently dilute as to not exceed local environmental air-quality standards. Additional buoyant plume rise above the physical stack top can further reduce ground-level concentrations.

Air-quality standards do not consider instantaneous samples of pollutant concentration. Instead, they are based on averages over time. For such averages, statistical descriptions of dispersion must be used, including the center of mass (plume centerline) and the standard deviation of location (proportional to plume spread).

For emissions in the boundary layer, the amount of dispersion depends on the type of turbulence. This relationship can be described by Taylor's statistical theory.

During daytime conditions of free convection, thermals cause a peculiar form of dispersion that often brings high concentrations of pollutants close to the ground. At night, turbulence is suppressed in the vertical, causing little dispersion. As pollutants remain aloft for this case, there is often little hazard at ground level. Turbulent dispersion is quite anisotropic for these convective and stable cases.

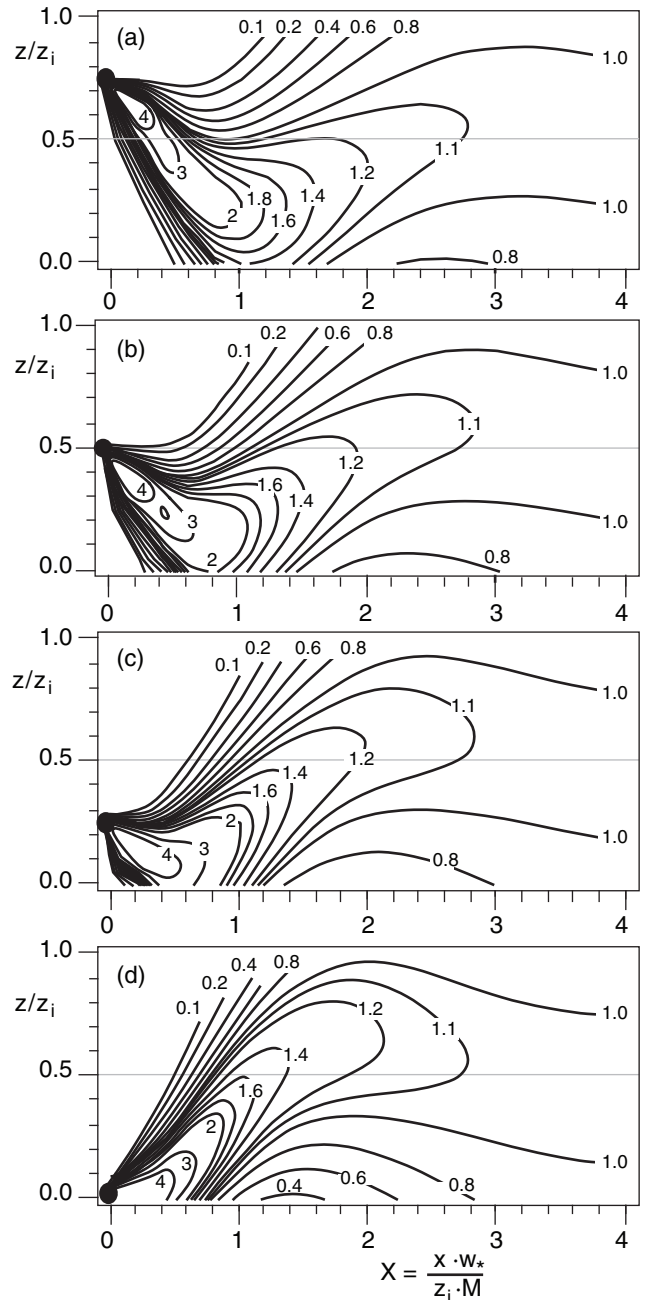

Figure 19.8 (at right)

Isopleths of dimensionless crosswind-integrated concentration $C_y = c_y \cdot z_i \cdot M / Q$ in a convective mixed layer, where c_y is crosswind integrated concentration, z_i is depth of the mixed layer, M is mean wind speed, and Q is emission rate of pollutants. Source heights are $Z_s = z_s/z_i =$ (a) 0.75, (b) 0.5, (c) 0.25, (d) 0.025, and are plotted as the large black dot at left.

Science Graffito

“The service we render to others is really the rent we pay for our room on the Earth.”
 – Sir Wilfred Grenfell.

Solved Example

Source emissions of 200 g/s of SO₂ occur at height 150 m. The environment is statically unstable, with a Deardorff convective velocity of 1 m/s, a mixed layer depth of 600 m, and a mean wind speed of 4 m/s.

Find the concentration at the ground 3 km downwind from the source, directly beneath the plume centerline.

Solution

Given: $Q = 200 \text{ g/s}$, $z_s = 150 \text{ m}$, $z_i = 600 \text{ m}$,
 $M = 4 \text{ m/s}$, $w_* = 1 \text{ m/s}$

Find: $c \text{ (}\mu\text{g/m}^3\text{)}$ at $x = 3 \text{ km}$, $y = z = 0$.

Use eq. (19.25):

$$X = \frac{(3000\text{m}) \cdot (1\text{m/s})}{(600\text{m}) \cdot (4\text{m/s})} = 1.25$$

Use eq. (19.29): $Z_s = (150\text{m}) / (600\text{m}) = 0.25$

From Fig. 19.8c, read $C_y \approx 0.9$ at $X = 1.25$ and $Z = 0$.

Use eq. (19.38): $\sigma_{yd} \approx 0.5 \cdot (1.25) = 0.625$

Use eq. (19.37) with $Y = 0$:

$$C = \frac{0.9}{\sqrt{2\pi} \cdot 0.625} = 0.574$$

Finally, use eq. (19.23) rearranging it first to solve for concentration in physical units:

$$c = \frac{C \cdot Q}{z_i^2 \cdot M} = \frac{(0.574) \cdot (200\text{g/s})}{(600\text{m})^2 \cdot (4\text{m/s})} = 79.8 \mu\text{g/m}^3$$

Check: Units OK. Physics OK.

Discussion: We were lucky that the dimensionless source height was 0.25, which allowed us to use Fig. 19.8c. For other source heights not included in that figure, we would have to create new figures using equations (19.33) through (19.36).

ON DOING SCIENCE • Citizen Scientist

Scientists and engineers have at least the same responsibilities to society as do other citizens. Like our fellow citizens, we ultimately decide the short-term balance between environmental quality and material wealth, by the goods that we buy and by the government leaders we elect. Be informed. Take a stand. Vote.

Perhaps we have more responsibility, because we can also calculate the long-term consequences of our actions. We have the ability to evaluate various options and build the needed technology. Take action.

Discover the facts. Design solutions.

In statically neutral conditions of overcast and strong winds, turbulence is more isotropic. Smoke plumes disperse at roughly equal rates in the vertical and lateral directions, and are well described by Gaussian formulae.

Various classification schemes have been designed to help determine the appropriate turbulence and dispersion characteristics. These range from the detailed examination of the production of turbulence kinetic energy, through examination of soundings plotted on thermo diagrams, to look-up tables such as those suggested by Pasquill and Gifford.

Finally, although we used the words “smoke” and “smoke stack” in this chapter, most emissions in North America and Europe are sufficiently clean that particulate matter is not visible. This clean-up has been expensive, but commendable.

Threads

Because most pollutants are emitted from near the surface, and most receptors are at the surface, the mean transport and turbulent dispersion of pollutants are primarily controlled by atmospheric boundary layer characteristics (Chapter 18). The nature of the turbulence depends on the radiatively driven (Chapter 2) heating (Chapter 3), and the dynamic forces and winds (Chapters 10 through 17). Many emissions, particularly from fuel combustion, contain water vapor (Chapter 4) as a combustion product, which can condense and form billowy white emission plumes.

Once emitted, the dispersion depends partly on the static stability (Chapter 5) of the ambient atmosphere. Cumulus clouds (Chapter 6) can withdraw pollutants out of the top of the ABL, and precipitation (Chapter 7) can scrub out some pollutants. The transport and dispersion of pollutants, and their interaction with weather (Chapters 12 and 13) and clouds, can be included as part of numerical weather forecasts (Chapter 20).

However, not all pollutants are immediately scrubbed out of the smoke plume, and can be carried by the global circulation (Chapter 11) to the whole globe, which could affect the climate (Chapter 21). As pollution concentrations increase, the visibility and color of the air is affected (Chapter 22) via the scattering and absorption of light.

EXERCISES

Numerical Problems

N1. Given the following pollutant concentrations in $\mu\text{m}/\text{m}^3$, convert to volume fraction units ppmv assuming standard sea-level conditions:

- a. SO_2 1300 b. SO_2 900 c. SO_2 365
- d. SO_2 300 e. SO_2 80 f. SO_2 60
- g. NO_2 400 h. NO_2 280 i. NO_2 200
- j. NO_2 150 k. NO_2 40 m. CO 40,000
- n. CO 35,000 o. CO 20,000 p. CO 15,000
- q. O_3 235 r. O_3 160 s. O_3 157
- t. O_3 100 u. O_3 50 v. O_3 30

N2. Same as previous exercise, but for a summer day in Denver, Colorado, USA, where $T = 25^\circ\text{C}$ and $P = 82 \text{ kPa}$.

N3. Create a table similar to Table 19-1, but where all the ppm values of volume fraction have been converted into concentration units of $\mu\text{g}/\text{m}^3$.

N4. Given wind measurements in the table below.

- a. Find the mean wind speed component in each direction
- b. Create a table showing the deviation from the mean at each time for each wind component.
- c. Find the velocity variance in each direction.
- d. Find the standard deviation of velocity for each wind direction.
- e. Determine if the turbulence is isotropic.
- f. Speculate on the cross-section shape of smoke plumes as they disperse in this atmosphere.

t (min)	U (m/s)	V (m/s)	W (m/s)
1	8	1	0
2	11	2	-1
3	12	0	1
4	7	-3	1
5	12	0	-1

N5. Determine the Pasquill-Gifford turbulence type

- a. Strong sunshine, clear skies, winds 1 m/s
- b. Thick overcast, winds 10 m/s, night
- c. Clear skies, winds 2.5 m/s, night
- d. Noon, thin overcast, winds 3 m/s.
- e. Cold air advection 2 m/s over a warm lake.
- f. Sunset, heavy overcast, calm.
- g. Sunrise, calm, clear.
- h. Strong sunshine, clear skies, winds 10 m/s.
- i. Thin overcast, nighttime, wind 2 m/s
- j. Thin overcast, nighttime, wind 5 m/s
- k. Thin overcast, 9 am, wind 3.5 m/s

N6. Given turbulence kinetic energy (TKE) buoyant generation (B) and shear generation (S) rates in this table (both in units of m^2s^{-3}), answer questions (i) - (vi) below.

	$\frac{B}{S}$	$\frac{S}{B}$		$\frac{B}{S}$	$\frac{S}{B}$
a.	0.004	0.0	k.	0.0	0.004
b.	0.004	0.002	m.	0.0	0.006
c.	0.004	0.004	n.	-0.002	0.0
d.	0.004	0.006	o.	-0.002	0.002
e.	0.002	0.0	p.	-0.002	0.004
f.	0.002	0.002	q.	-0.002	0.006
g.	0.002	0.004	r.	-0.004	0.0
h.	0.002	0.006	s.	-0.004	0.002
i.	0.0	0.0	t.	-0.004	0.004
j.	0.0	0.002	u.	-0.004	0.006

- (i) Specify the nature of flow/convection
- (ii) Estimate the Pasquill-Gifford turbulence type.
- (iii) Classify the static stability (from strongly stable to strongly unstable)
- (iv) Estimate the **flux Richardson number**
 $R_f = -B/S$
- (v) Determine the dispersion isotropy
- (vi) Is turbulence intensity (TKE) strong or weak?

N7. Given the table below with pollutant concentrations c ($\mu\text{g}/\text{m}^3$) measured at various heights z (km), answer these 5 questions.

- (i) Find the height of center of mass.
- (ii) Find the vertical height variance.
- (iii) Find the vertical height standard deviation.
- (iv) Find the total amount of pollutant emitted.
- (v) Find the nominal plume spread (depth)

z (km)	c ($\mu\text{g}/\text{m}^3$)				
Question:	a	b	c	d	e
1.5	0	0	0	0	0
1.4	0	10	0	86	0
1.3	5	25	0	220	0
1.2	25	50	0	430	0
1.1	20	75	0	350	0.04
1.0	45	85	0	195	0.06
0.9	55	90	2	50	0.14
0.8	40	93	8	5	0.18
0.7	30	89	23	0	0.13
0.6	10	73	23	0	0.07
0.5	0	56	7	0	0.01
0.4	0	30	3	0	0
0.3	0	15	0	0	0
0.2	0	5	0	0	0
0.1	0	0	0	0	0

N8.(S) For the previous problem, find the best-fit Gaussian curve through the data, and plot the data and curve on the same graph.

N9. Using the data from question N7, find the nominal plume width from edge to edge.

- a. 0 b. 0.1 c. 0.2 d. 0.3 e. 0.4 f. 0.5 g. 0.7
h. 1 i. 1.5 j. 2 k. 3 m. 4 n. 5 o. 6

N10. Given lateral and vertical velocity variances of 1.0 and 0.5 m²/s², respectively. Find the variance of plume spread in the lateral and vertical, at distance 3 km downwind of a source in a wind of speed 5 m/s. Use a Lagrangian time scale of:

- a. 15 s b. 30 s c. 1 min d. 2 min
e. 5 min f. 10 min g. 15 min h. 20 min
i. 5 s j. 45 s m. 12 min n. 30 min

N11.(§) For a Lagrangian time scale of 2 minutes and wind speed of 10 m/s, plot the standard deviation of vertical plume spread vs. downwind distance for a vertical velocity variance (m²/s²) of:

- a. 0.1 b. 0.2 c. 0.3 d. 0.4 e. 0.5
f. 0.6 g. 0.8 h. 1.0 i. 1.5 j. 2
k. 2.5 m. 3 n. 4 o. 5 p. 8

N12.(§) For the previous problem, plot σ_z if
(i) only the near-source equation
(ii) only the far source equation
is used over the whole range of distances.

N13. Given the following emission parameters:

	W_o (m/s)	R_o (m)	$\Delta\theta$ (K)
a.	5	3	200
b.	30	1	50
c.	20	2	100
d.	2	2	50
e.	5	1	50
f.	30	2	100
g.	20	3	50
h.	2	4	20

Find the momentum and buoyant length scales for the plume-rise equations. Assume $|g|/\theta_a \approx 0.0333$ m·s⁻²·K⁻¹, and $M = 5$ m/s for all cases.

N14.(§) For the previous problem, plot the plume centerline height vs. distance if the physical stack height is 100 m and the atmosphere is statically neutral.

N15. For buoyant length scale of 5 m, physical stack height 10 m, environmental temperature 10°C, and wind speed 2 m/s, find the equilibrium plume centerline height in a statically stable boundary layer, given ambient potential temperature gradients of $\Delta\theta/\Delta z$ (K/km):

- a. 1 b. 2 c. 3 d. 4 e. 5 f. 6 g. 7
h. 8 i. 9 j. 10 k. 12 m. 15 n. 18 o. 20

N16. Given $\sigma_y = \sigma_z = 300$ m, $z_{CL} = 500$ m, $z = 200$ m, $Q = 100$ g/s, $M = 10$ m/s. For a neutral boundary layer, find the concentration at y (km) =

N17.(§). Plot the concentration footprint at the surface downwind of a stack, given: $\sigma_v = 1$ m/s, $\sigma_w = 0.5$ m/s, $M = 2$ m/s, Lagrangian time scale = 1 minute, $Q = 400$ g/s of SO₂, in a stable boundary layer. Use a plume equilibrium centerline height (m) of:

- a. 10 b. 20 c. 30 d. 40 e. 50 f. 60 g. 70
h. 15 i. 25 j. 35 k. 45 m. 55 n. 65 o. 75

N18. Calculate the dimensionless downwind distance, given a convective mixed layer depth of 2 km, wind speed 3 m/s, and surface kinematic heat flux of 0.15 K·m/s. Assume $|g|/T_v \approx 0.0333$ m·s⁻²·K⁻¹. The actual distance x (km) is:

- a. 0.2 b. 0.5 c. 1 d. 2 e. 3 f. 4
g. 5 h. 7 i. 10 j. 20 k. 30 m. 50

N19. If $w_* = 1$ m/s, mixed layer depth is 1 km, wind speed is 5 m/s, $Q = 100$ g/s, find the

- a. dimensionless downwind distance at $x = 2$ km
b. dimensionless concentration if $c = 100$ µg/m³
c. dimensionless crosswind integrated concentration if $c_y = 1$ mg/m²

N20.(§) For a convective mixed layer, plot dimensionless plume centerline height with dimensionless downwind distance, for dimensionless source heights of:

- a. 0 b. 0.01 c. 0.02 d. 0.03 e. 0.04
f. 0.05 g. 0.06 h. 0.07 i. 0.08 j. 0.09
k. 0.1 m. 0.12 n. 0.15 o. 0.2 p. 0.22

N21.(§) For the previous problem, plot isopleths of dimensionless crosswind integrated concentration, similar to Fig. 19.8, for convective mixed layers.

N22. Source emissions of 300 g/s of SO₂ occur at height 200 m. The environment is statically unstable, with a Deardorff convective velocity of 1 m/s, and a mean wind speed of 5 m/s.

Find the concentration at the ground at distances 1, 2, 3, and 4 km downwind from the source, directly beneath the plume centerline. Assume the mixed layer depth (km) is:

- a. 0.5 b. 0.75 c. 1.0 d. 1.25 e. 1.5 f. 1.75
g. 2.0 h. 2.5 i. 3.0 j. 3.5 k. 4.0 m. 5.0
(Hint: Interpolate between figures if needed, or derive your own figures.)

Understanding & Critical Evaluation

U1. Compare the two equations for variance: (19.5) and (19.9). Why is the one weighted by pollution concentration, and the other not?

U2. To help understand complicated figures such as Fig. 19.3, it helps to separate out the various parts. Using the info from that figure, produce a separate sketch of the following on a background grid of B and S values:

- TKE (arbitrary relative intensity)
- R_f
- Flow type
- Static stability
- Pasquill-Gifford turbulence type
- Dispersion isotropy (plume cross section)
- Suggest why these different variables are related to each other.

U3. Fig. 19.3 shows how dispersion isotropy can change as the relative magnitudes of the shear and buoyancy TKE production terms change. Also, the total amount of spread increases as the TKE intensity increases. Discuss how the shape and spread of smoke plumes vary in different parts of that figure, and sketch what the result would look like to a viewer on the ground.

U4. Eq. (19.8) gives the center of mass (i.e., plume centerline height) in the vertical direction. Create a similar equation for plume center of mass in the horizontal, using a cylindrical coordinate system centered on the emission point.

U5. In eq. (19.10) use $Q_1 = 100$ g/m and $\bar{z} = 0$. Plot on graph paper the Gaussian curve using σ_z (m) =

- 100
- 200
- 300
- 400

Compare the areas under each curve, and discuss the significance of the result.

U6. Why does a “nominal” plume edge need to be defined? Why cannot the Gaussian distribution be used, with the definition that plume edge happens where the concentration becomes zero. Discuss, and support your arguments with results from the Gaussian distribution equation.

U7. The Lagrangian time scale is different for different size eddies. In nature, there is a superposition of turbulent eddies acting simultaneously. Describe the dispersion of a smoke plume under the influence of such a spectrum of turbulent eddies.

U8. While Taylor’s statistical theory equations give plume spread as a function of downwind distance, x , these equations are also complex functions of the Lagrangian time scale t_L . For a fixed value of downwind distance, plot curves of the variation of plume

spread (eq. 19.13) as a function of t_L . Discuss the meaning of the result.

U9. a. Derive eqs. (19.14) and (19.15) for near-source and far-source dispersion from Taylor’s statistical theory equations (19.13).

b. Why do the near and far source dispersion equations appear as straight lines in a log-log graph (see the solved example near eq. (19.15))?

U10. Plot the following sounding on the boundary-layer $\theta - z$ thermo diagram from the Stability chapter. Determine the static stability vs. height. Determine boundary-layer structure, including location and thickness of components of the boundary layer (surface layer, stable BL or convective mixed layer, capping inversion or entrainment zone, free atmosphere). Speculate whether it is daytime or nighttime, and whether it is winter or summer. For daytime situations, calculate the mixed-layer depth. This depth controls pollution concentration (shallow depths are associated with periods of high pollutant concentration called **air-pollution episodes**, and during calm winds to **air stagnation events**). [Hint: Review how to nonlocally determine the static stability, as given in the ABL and Stability chapters.]

z (m)	a. T (°C)	b. T (°C)	c. T (°C)	d. T (°C)
2500	-11	8	-5	5
2000	-10	10	-5	0
1700	-8	8	-5	3
1500	-10	10	0	5
1000	-5	15	0	10
500	0	18	5	15
100	4	18	9	20
0	7	15	10	25

U11. For the ambient sounding of the previous exercise, assume that a smoke stack of height 100 m emits effluent of temperature 6°C with water-vapor mixing ratio 3 g/kg. (Hint, assume the smoke is an air parcel, and use a thermo diagram.)

- How high would the plume rise, assuming no dilution with the environment?
- Would steam condense in the plume?

U12. For plume rise in statically neutral conditions, write a simplified version of the plume-rise equation (19.16) for the special case of:

- momentum only
- buoyancy only

Also, what are the limitations and range of applicability of the full equation and the simplified equations?

U13. For plume rise in statically stable conditions, the amount of rise depends on the Brunt-Väisälä fre-

quency. As the static stability becomes weaker, the Brunt-Väisälä frequency changes, and so changes the plume centerline height. In the limit of extremely weak static stability, compare this plume rise equation with the plume rise equation for statically neutral conditions. Also, discuss the limitations of each of the equations.

U14. In eq. (19.20), the “reflected” part of the Gaussian concentration equation was created by pretending that there is an imaginary source of emissions an equal distance underground as the true source is above ground. Otherwise, the real and imaginary sources are at the same horizontal location and have the same emission rate.

In eq. (19.20), identify which term is the “reflection” term, and show why it works as if there were emissions from below ground.

U15. In the solved example in the Gaussian Concentration Distribution subsection, the concentration footprints at ground level have a maximum value neither right at the stack, nor do concentrations monotonically increase with increasing distances from the stack. Why? Also, why are the two figures in that solved example so different?

U16. Show that eq. (19.20) reduces to eq. (19.21) for receptors at the ground.

U17. For Gaussian concentration eq. (19.21), how does concentration vary with:

- a. σ_y b. σ_z c. M

U18. Give a physical interpretation of crosswind integrated concentration, using a different approach than was used in Fig. 19.6.

U19. For plume rise and pollution concentration in a statically unstable boundary layer, what is the reason for, or advantage of, using dimensionless variables?

U20. If the Deardorff velocity increases, how does the dispersion of pollutants in an unstable boundary layer change?

U21. In Fig. 19.8, at large distances downwind from the source, all of the figures show the dimensionless concentration approaching a value of 1.0. Why does it approach that value, and what is the significance or justification for such behavior?

Web-Enhanced Questions

W1. Search the web for the government agency of your country that regulates air pollution. In the USA, it is the Environmental Protection Agency (EPA). Find the current air pollution standards for the chemicals listed in Table 19-1.

W2. Search the web for an air quality report for your local region (such as town, city, state, or province). Determine how air quality has changed during the past decade or two.

W3. Search the web for a site that gives current air pollution readings for your region. In some cities, this pollution reading is updated every several minutes, or every hour. If that is the case, see how the pollution reading varies hour by hour during a typical workday.

W4. Search the web for information on health effects of different exposures to different pollutants.

W5. Air-pollution models are computer codes that use equations similar to the ones in this chapter, to predict air-pollution concentration. Search the web for a list of names of a few of the popular air-pollution models endorsed by your country or region.

W6. Search the web for inventories of emission rates for pollutants in your regions. What are the biggest polluters?

W7. Search the web for an explanation of **emissions trading**. Discuss why such a policy is or is not good for industry, government, and people.

W8. Search the web for information on **acid rain**. What is it? How does it form? What does it do?

W9. Search the web for information on **forest death (waldsterben)** caused by pollution or acid rain.

W10. Search the web for instruments that can measure concentration of the chemicals listed in Table 19-1.

W11. Search the web for “web-cam” cameras that show a view of a major city, and discuss how the visibility during fair weather changes during the daily cycle on a workday.

W12. Search the web for information of plume rise and/or concentration predictions for complex (mountainous) terrain.

W13. Search the web for information to help you discuss the relationship between “good” ozone in the stratosphere and mesosphere, vs. “bad” ozone in the boundary layer.

W14. For some of the major industry in your area, search the web for information on control technologies that can, or have, helped to reduce pollution emissions.

W15. Search the web for satellite photos of emissions from major sources, such as a large industrial complex, smelter, volcano, or a power plant. Use the highest-resolution photographs to look at lateral plume dispersion, and compare with the dispersion equations in this chapter.

W16. Search the web for information on forward or backward trajectories, as used in air pollution. One example is the Chernobyl nuclear accident, where radioactivity measurements in Scandinavia were used with a back trajectory to suggest that the source of the radioactivity was in the former Soviet Union.

W17. Search the web for information on chemical reactions of air pollutants in the atmosphere.

W18. Search the web for satellite photos and other information on an **urban plume** (the pollutant plume downwind of a whole city).

W19. To simplify the presentation of air-quality data to the general public, many governments have created an **air-quality index** that summarizes with a simple number how clean or dirty the air is. For your national government (or for the USA if your own government doesn't have one), search the web for info about the air-quality index. How is it defined in terms of concentrations of different pollutants? How do you interpret the index value in terms of visibility and/or health hazards?

Synthesis Questions

S1. Suppose that there was not a diurnal cycle, but that the atmospheric temperature profile was steady, and equal to the standard atmosphere. How would local and global dispersion of pollutants from tall smoke stacks be different, if at all?

S2. In the present atmosphere, larger-size turbulent eddies often have more energy than smaller size one. What if the energy distribution were reversed, with the vigor of mixing increasing as eddy sizes decrease. How would that change local dispersion, if at all?

S3. What if tracers were not passive, but had a special magnetic attraction only to each other. Describe how dispersion would change, if at all.

S4. What if a plume that is rising in a statically neutral environment has buoyancy from both the initial temperature of the effluent out of the top of the stack, and also from additional heat gained while it was dispersing.

A real example was the black smoke plumes from the oil well fires during the Gulf War. Sunlight was strongly absorbed by the black soot and unburned petroleum in the smoke, causing solar warming of the black smoke plume.

Describe any resulting changes to plume rise.

S5. Suppose that smoke stacks produced smoke rings, instead of smoke plumes. How would dispersion be different, if at all?

S6. When pollutants are removed from exhaust gas before the gas is emitted from the top of a smoke stack, those pollutants don't magically disappear. Instead, they are converted into water pollution (to be dumped into a stream or ocean), or solid waste (to be buried in a dump or landfill). Which is better? Why?

S7. Propose methods whereby life on Earth could produce zero pollution. Defend your proposals.

S8. What if the same emission rate of pollutions occurs on a fair-weather day with light winds, and an overcast rainy day with stronger winds. Compare the dispersion and pollution concentrations at the surface for those situations. Which leads to the least concentration at the surface, locally? Which is better globally?

S9. Suppose that all atmospheric turbulence was extremely anisotropic, such that there was zero dispersion in the vertical, but normal dispersion in the horizontal.

a. How would that affect pollution concentrations at the surface, for emissions from tall smoke stacks?

b. How would it affect climate, if at all?

S10. What if ambient wind speed was exactly zero. Discuss the behavior of emission plumes, and how the resulting plume rise and concentration equations would need to be modified.

S11. What if pollutants that were emitted into the atmosphere were never lost or removed from the

atmosphere. Discuss how the weather and climate would be different, if at all?

S12. If there were no pollutants in the atmosphere (and hence no cloud and ice nuclei), discuss how the weather and climate would be different, if at all.

S13. Divide the current global pollutant emissions by the global population, to get the net emissions per person. Given the present rate of population increase, discuss how pollution emissions will change over the next century, and how it will affect the quality of life on Earth, if at all.