

UBC ATSC 303 2023W

Lab 1 – Circuits (/85)

Teaching assistant: Davi Monticelli (Davi, Dave, David – all good. He/Him/His)

E-mail: dmonticelli@eoas.ubc.ca

Quick resources:

- Circuits : <https://www.allaboutcircuits.com/textbook/direct-current/chpt-5/building-simple-resistor-circuits/>
- Breadboards: <https://www.youtube.com/watch?v=6WReFkfrUIk>
- Multimeters: <https://www.youtube.com/watch?v=ts0EVc9vXcs>

Learning goals

- 1) Lab Safety and procedures
- 2) How to handle equipment (check-out and check-in)
- 3) Learn to build simple circuits (series, parallel, and bridge)
- 4) Learn to use a multimeter
- 5) Learn how to apply Ohm's and Kirchhoff's Laws to (series, parallel, and bridge) circuits.

Background

Circuits Review

Brock Appendix D and Harrison Ch 3.

Safety

- A general overview of the lab (know where the fire extinguisher is located)
- There is a low risk of electric shock when handling the ELEGOO Resistor Wires and Breadboards. The most important rule is to not stick any foreign objects into the breadboard... ONLY the material provided.
- Have spatial awareness of the equipment you are working with; it can cause harm to others (e.g., don't poke other students with the multimeter prongs).

Due to limited equipment, we will be working in groups.

Experiment:

Equipment needed:

(Your group needs to check-out and check-in everything listed below)

- Breadboard
- 9V Battery
- Three 1 k Ω Resistors
- One 470 Ω Resistor
- One 2.2 k Ω Resistor
- Two resistors with unknown resistance (covered in colored electrical tape, please do not remove the tape or you ruin the fun of the lab)
- Three jumpers (small connecting wires – NOTE: you'll only need two, but one is provided as a backup)
- Multimeter
 - Make sure to set the dial to the correct setting BEFORE it encounters any wires.
 - To measure voltage, set the dial to “V” (you may need to press SEL on the orange multimeter to change to DC). **The multimeter prongs should be in parallel** to the portion of the circuit you are trying to measure.
 - To measure current, set the dial to “mA” (you may need to press SEL on the orange multimeter to change to DC). The multimeter prongs must be in serial to the portion of the circuit you are trying to measure. **Hence, the multimeter should form part of the circuit**; you will need to break the circuit to ensure that the prongs complete it.
 - **DO NOT MEASURE THE CURRENT OF A CIRCUIT WITHOUT RESISTORS** (i.e., do not, accidentally, or otherwise, measure the current across the terminals of the battery). **You will fry the multimeter or cause the battery to heat up dangerously.**
 - To measure the resistance of a resistor, set the dial to the setting with the Ω symbol. The resistor must be disconnected from the circuit, and the multimeter prongs must be in contact with both legs of the resistor.

Methods/Experiment

Part 0 – Battery Voltage

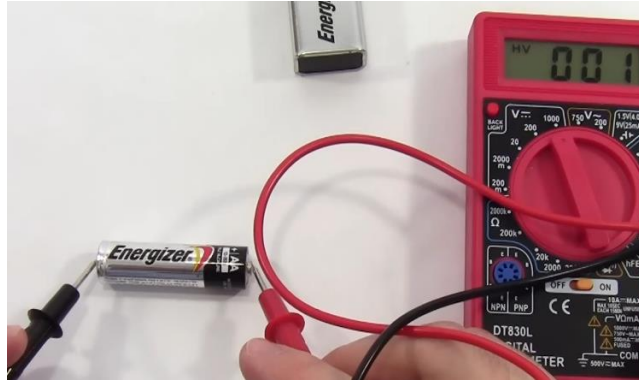

- 1) Imagine you just measured the **voltage** of a battery (like in the figure above), and the multimeter display a value of 8.9V. If you flip the prongs and measure and record them again, what would you see from the multimeter reading? Why is that the case? **(/2)**
- 2) In the image above, what could be the reason that the reading is 0.01 and not 8.9? **(/1)**

Part 1 - Simple Circuit (check QUICK REFERENCES at the end for more guidance)

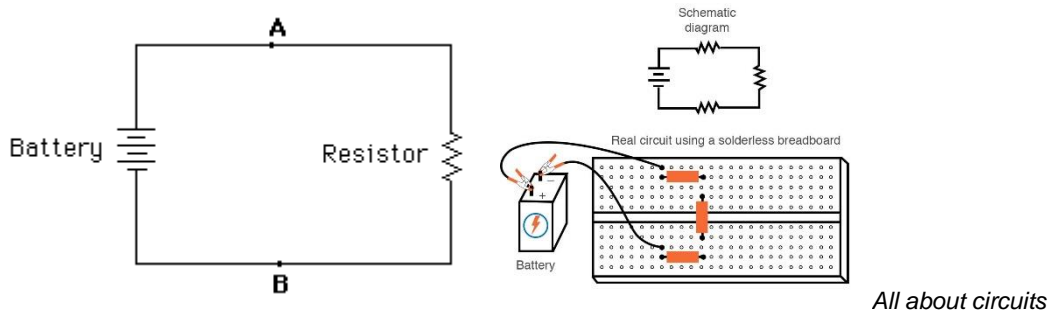

Imagine you connected the battery in series with a 1kΩ resistor (similar to the left figure above).

- 1) Assume you measured and recorded the **voltage** across the resistor. Should it differ from the voltage of the battery? Why or why not? **(/2)**
- 2) Calculate the current based on Ohm's Law: **(/1)**

$$V = I * R$$

- 3) Assume you measured and recorded the **current** at A and B.
 - a) How does the current compare on both sides of the resistor? What law does your finding satisfy? **(/3)**
 - a) If the measured value was 8.8mA How close was your calculation compared to what was measured? What might be some sources of error that could have caused this discrepancy? **(/2)**

Part 2 - Voltage Divider (check QUICK REFERENCES at the end for more guidance)

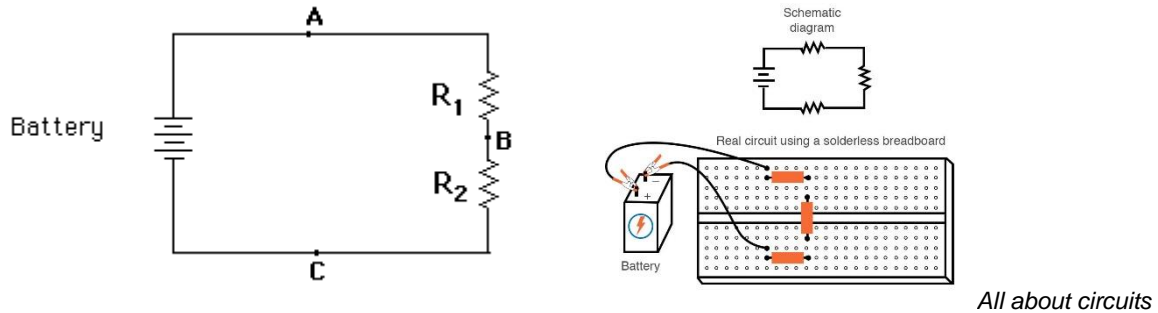

Assume you connected two known resistors in series (as shown in the left figure above).

- a) $R_1 = 470 \Omega$
 - b) $R_2 = 1 \text{ k}\Omega$
- 2) Answer the following questions
 - a) Compute the voltages V_{AB} (i.e. across R_1 , between points A and B), V_{BC} (i.e. across R_2 , between points B and C), and V_{AC} (i.e. across both resistors, between points A and C). **(/3)**
 - b) How does V_{AC} relate to V_{AB} and V_{BC} ? **(/1)**
 - c) How does V_{AC} compare with the voltage across the single resistor in Part 1? **(/1)**
 - 3) Calculate the current based on Ohm's Law across R_1 , R_2 , and across both resistors, using the voltages you measured earlier. **(/3)**

Assume you disconnected the known resistor R_2 and replaced with an unknown resistor

- a) If $V_{BC} = 0.814 \text{ V}$, what values should we expect for V_{AB} , and V_{AC} . **(/4)**
- b) Compute the resistance (Ω) of the unknown resistor. **(/2)**
- c) You have a resistor with the following bands (from left to right): Brown, Black, Black, Black, Brown. What is the manufactured resistance? State clearly how you determined your answer. **(/3)**
- a) How does your calculated resistance compare to the manufactured specifications? Why do you see discrepancies between the resistances? **(/5)**

Part 3 - Circuit in Parallel (check QUICK REFERENCES at the end for more guidance)

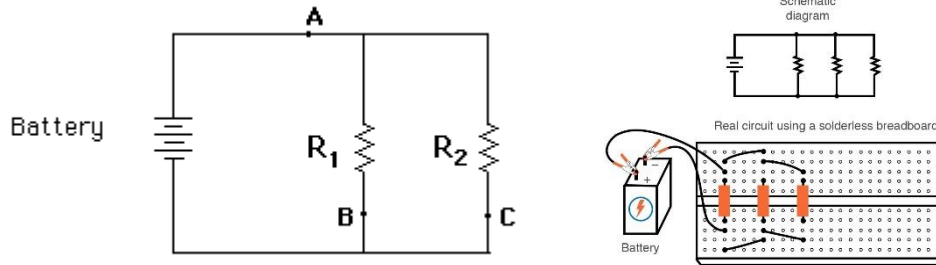

All about circuits

Imagine you connected two known resistors in parallel (as shown in the left figure above)

- a) $R_1 = 2.2 \text{ k}\Omega$
 - b) $R_2 = 1 \text{ k}\Omega$
- 1) What are the voltages V_{AB} , and V_{AC} . **(/2)**
 - 2) Calculate the current based on Ohm's Law at locations A, B, and C. **(/3)**
 - 3)
 - a) How does the current at A relate to the currents at B and C? **(/2)**
 - b) What do you notice about the ratio of currents at B and C, and the ratio of the resistances? **(/3)**
 - 4) Suppose R_1 and R_2 were connected in series instead. What would be the total resistance of the circuit, and how does this compare to the total resistance of the parallel circuit above? **(/3)**

Part 4 - Bridge Circuit (check QUICK REFERENCES at the end for more guidance)

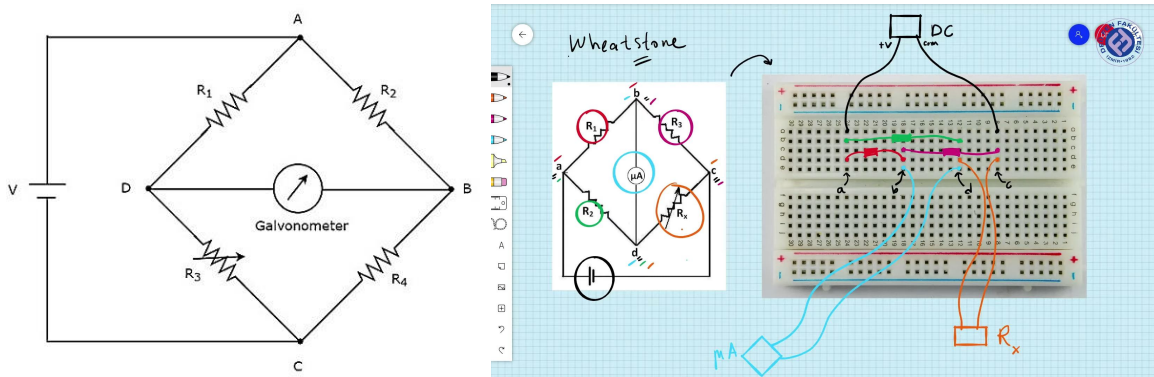

Imagine you connected three known and one unknown resistor (**Green**) in a bridge circuit (as shown in the left figure above).

- a) $R_1 = 1 \text{ k}\Omega$
- b) $R_2 = 1 \text{ k}\Omega$

- c) $R_3 = \text{Unknown } \Omega$
 - d) $R_4 = 1 \text{ k}\Omega$
- 2) Calculate the resistance of R_3 by setting the multimeter to measure the voltage V_{DB} with the positive lead (red) of multimeter at junction D. Assume you measured -2.88V . What is the calculated resistance of the unknown R_3 ? **(/4)**
- 3) Calculate the resistance of R_3 by measuring the voltages V_{AD} and V_{AC} with the positive lead (red) of voltmeter at junction A.
- a) Assume you measured $V_{AD} = 7.38\text{V}$ and $V_{AC} = 9.0\text{V}$ What is the calculated resistance of the unknown R_3 ? **(/3)**
 - b) You have a resistor with the following bands (from left to right): Red, Red, Black, Black, Brown. What is the manufactured resistance? State clearly how you determined your answer. **(/2)**
 - c) How does this compare with what you calculated in the previous question? **(/2)**

****** END OF MEASUREMENTS ******

Concept Questions (based on lab/lecture/demo and readings)

- 1) If you double the resistance of R_2 and R_4 in the bridge circuit in Part 4, what would be the new voltage drop across V_{DB} ? **(/2)**
- 2) Suppose the resistance R_3 you computed in Question 2 of Part 4 increased by 0.01 % because of a change in temperature. Assuming all other resistors are the same, what is the new value of V_{DB} ? **(/3)**
- 3) What is the new voltage drop across resistor R_1 , V_{AD} ? **(/2)**
- 4) Based on your answers to questions 2 and 3, why do we use bridge circuits in the field of atmospheric science? **(/3)**
- 5) Suppose R_2 in the bridge circuit was removed, i.e., junctions A and B are disconnected. Assuming the temperature is back to what it was (i.e., using the resistance R_3 you computed in Part 4), what are the new voltages and currents:
 - a) Across R_1 ? **(/2)**
 - b) Across R_3 ? **(/2)**
 - c) Across R_4 ? **(/2)**
- 6) For a circuit with a capacitor of unknown capacitance C and a resistor with known resistance $1\text{ k}\Omega$, compute the capacitance if the e-folding time is:
 - a) 0.2 s **(/2)**
 - b) 0.4 s **(/2)**
- 7) For a circuit with a capacitor of unknown capacitance C and a resistor with known resistance $470\ \Omega$, estimate the capacitance given the following voltage data. Show how you obtained your answer --- see table on the next page. **(/5)**

t (s)	Voltage (V)
0	0.00
0.5	3.47
1.0	5.73
1.5	7.21
2.0	8.18
2.5	8.81
3.0	9.22
3.5	9.49
4.0	9.67
4.5	9.78
5.0	9.86
5.5	9.91
6.0	9.94
6.5	9.96
7.0	9.97
7.5	9.98
8.0	9.99
8.5	9.99
9.0	10.00
9.5	10.00
10.0	10.00

8) What might be some sources of error in trying to estimate the capacitance with the table above? (13)

QUICK REFERENCES:

Good ways to measure the Voltage of a simple circuit

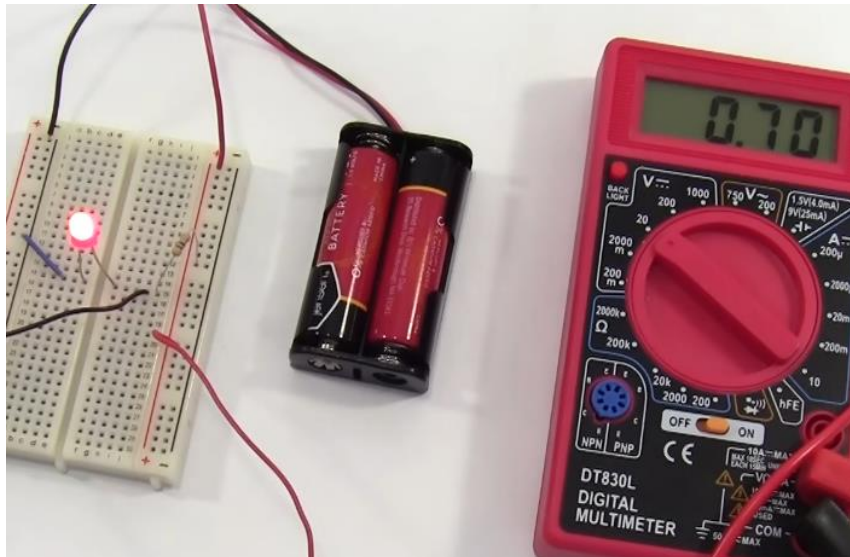
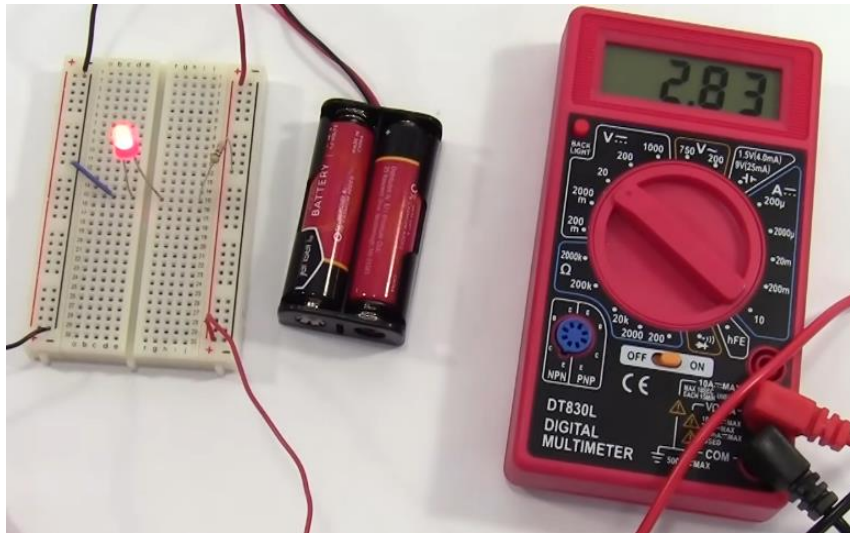
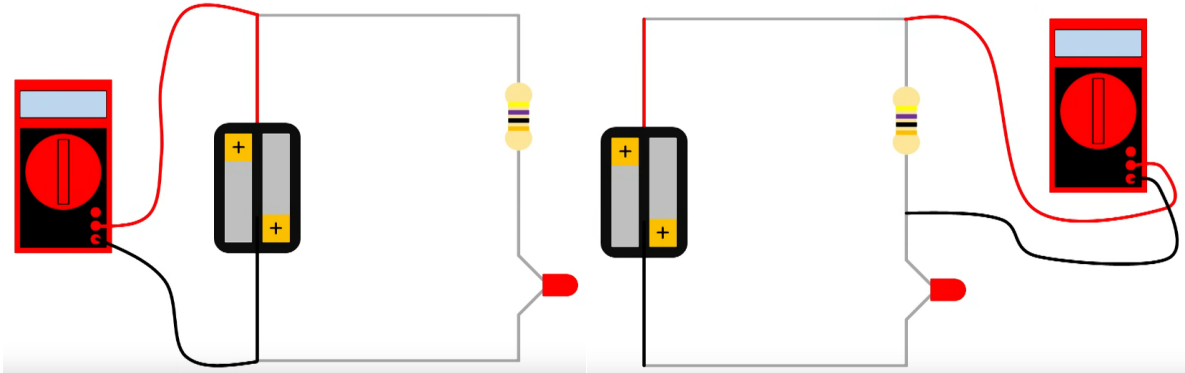

Good ways to measure the Current of a simple circuit

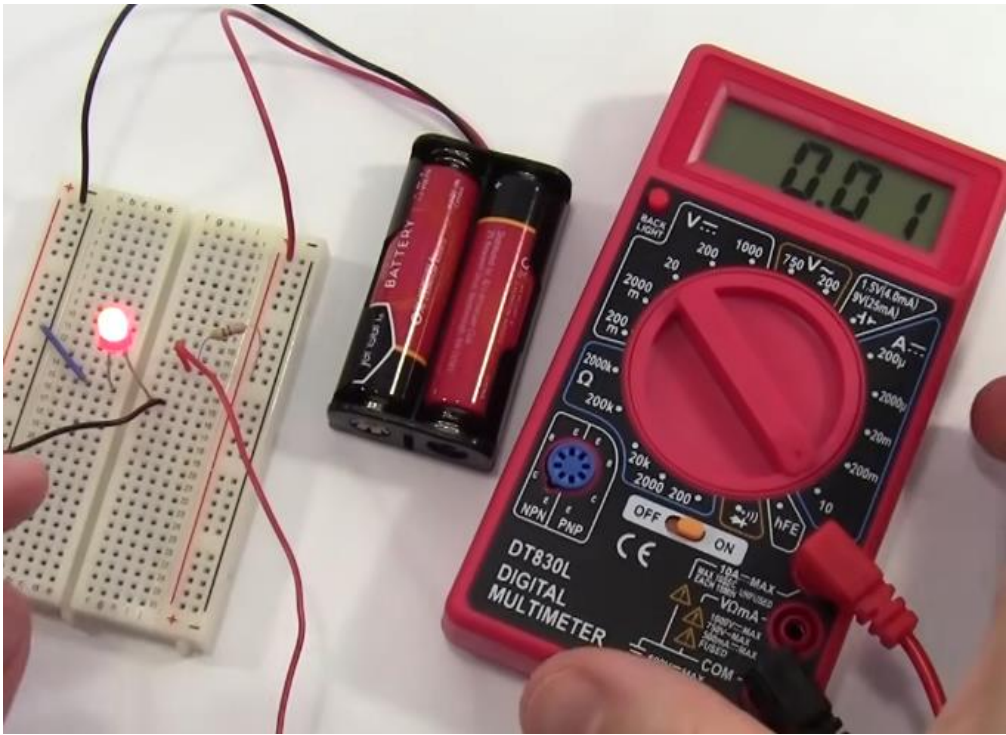
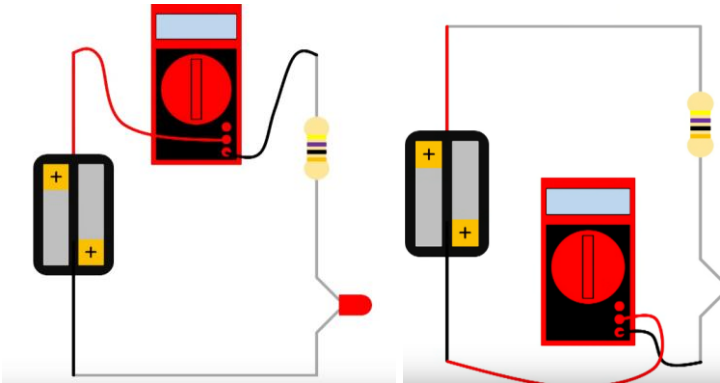

Good ways to measure the Resistance of a simple resistor

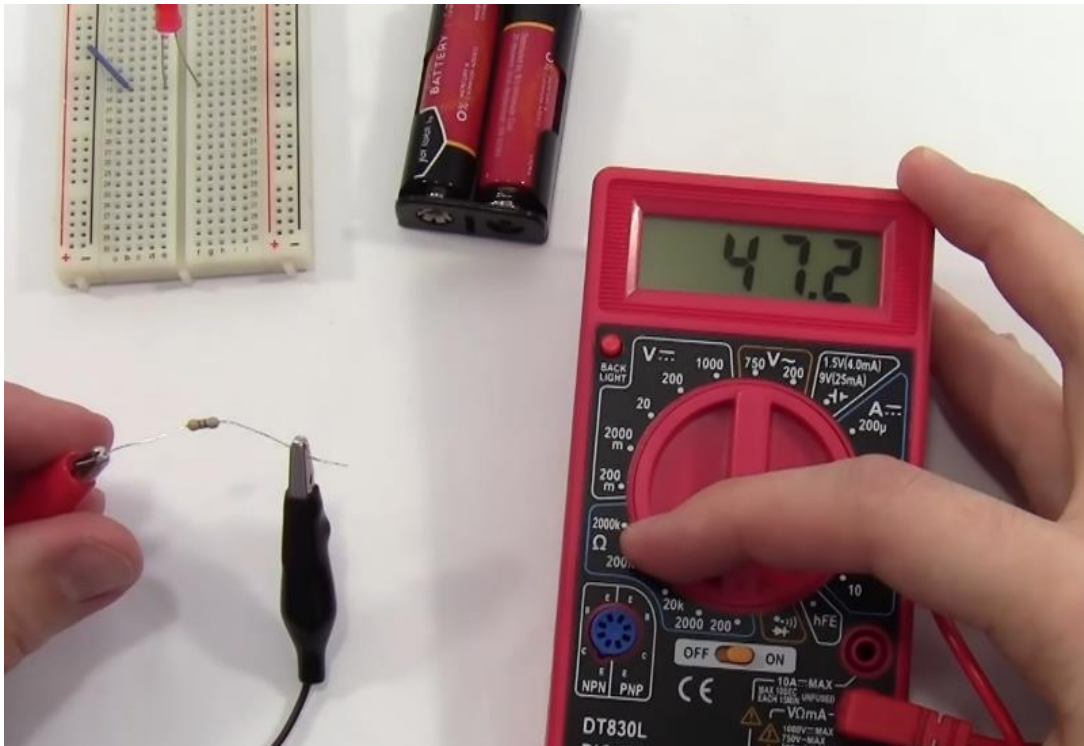



www.elegoo.com

Contact us :
 US&CA Customer: service@elegoo.com
 Europe Customer: EUservice@elegoo.com

5 Color Band Resistor
237Ω ±1%

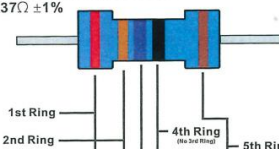

1st Ring
2nd Ring
3rd Ring
4th Ring (the multiplier)
5th Ring

4 Color Band Resistor
560KΩ ±1%

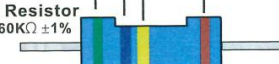

Color	1st Ring	2nd Ring	3rd Ring	4th Ring (Multiplier)	5th Ring (Tolerance)
Black	0	0	0	1	
Brown	1	1	1	10	±1%
Red	2	2	2	100	±2%
Orange	3	3	3	1	
Yellow	4	4	4	10	
Green	5	5	5	100	±0.5%
Blue	6	6	6	1	±0.25%
Violet	7	7	7	10	±0.10%
Gray	8	8	8		±0.05%
White	9	9	9		
Gold				0.1	±5%
Silver				0.01	±10%
No Color					±20%

- 25PCS 0Ω ±1%
- 25PCS 100kΩ ±1%
- 25PCS 10Ω ±1%
- 25PCS 220kΩ ±1%
- 25PCS 20Ω ±1%
- 25PCS 470kΩ ±1%
- 25PCS 47Ω ±1%
- 25PCS 1MΩ ±1%
- 25PCS 470Ω ±1%
- 50PCS 100Ω ±1%
- 25PCS 2.2kΩ ±1%
- 50PCS 220Ω ±1%
- 25PCS 4.7kΩ ±1%
- 50PCS 1kΩ ±1%
- 25PCS 22kΩ ±1%
- 50PCS 10kΩ ±1%
- 25PCS 47kΩ ±1%

Circuit of a Wheatstone Bridge

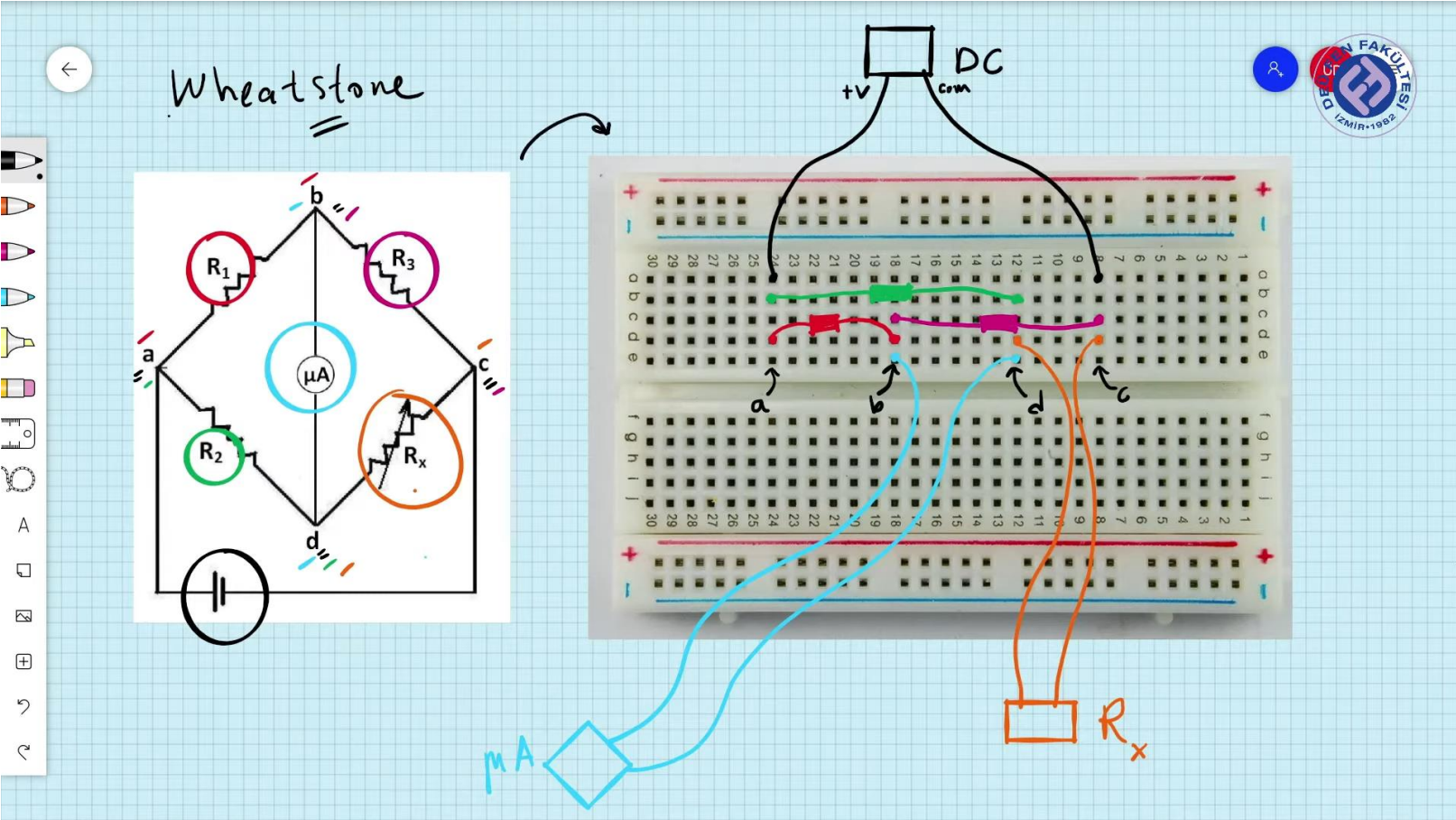

<https://www.youtube.com/watch?v=qZocxkKGkKo>